

# DHF TS 013-1:2021 - Code of practice for the safety of industrial doors, domestic garage doors, powered gates & traffic barriers

## Part 1: On-site guide



---

## Foreword

This guide draws on applicable legislation and standards to assist all those installing, commissioning, repairing, and maintaining industrial doors, domestic garage doors, powered gates & traffic barrier installations on site.

Manufacturers engaged in type testing & UKCA/CE marking for serial production compliance should follow the current version of the relevant standard (using an approved/notified body where required by the Construction Products Regulations 2013), rather than use this guide:

- 1) EN 13421 for Construction Products Regulations 2013 (CPR), and
- 2) EN 12453 for Supply of Machinery (Safety) Regulations (Machinery Directive).

The minimum level of safety required for legal compliance is mostly defined by the applicable British and European standards. Users of this guide are reminded that product specific standards represent the legal minimum level of safety acceptable in legislation (variously the state-of-the-art or “reasonably practicable” measures depending on legal jurisdiction) and hence, where these standards are not followed, an equal or improved level of safety must still be achieved.

**The term ‘state-of-the-art’ has various meanings in differing environments. In this environment, it is not ‘cutting edge’ or ‘best possible’, it is simply the level of safety described in the current standard.**

Account must also be taken of the fact that the 2000 version of EN 12453 (BS EN 12453:2001 in the UK) was called into doubt by UK HSE in 2011 & 2014, and that their objections were upheld by the European Commission in 2015. The Commission also declined to ‘harmonise’ the later 2017 revision. It is expected that, when the A1 amendment is published (EN 12453:2017+A1), it will be given ‘harmonised’ status, conferring a presumption of conformity with the Machinery Directive. This should then lead the UK government to add the A1:2021 amendment to its list of ‘designated’ standards, in turn allowing users a presumption of conformity with the Supply of Machinery (Safety) Regulations 2008.

The advice given in this guide strives to address all compliance shortfalls arising from any lack of harmonised or designated status. This is done to protect the safety and legal interests of users, service providers and owner groups.

The UK has now left the European Union; UK legislation and standards now take precedence in GB. For convenience and simplicity, we refer to the UK versions of the legislation, with reference to the European version in brackets where necessary. In the Republic of Ireland and Northern Ireland, subtle differences apply but, in general, the meaning and result is the same.

More detailed advice on the applicable legislation and UKCA/CE marking related subjects is available in the DHF guide to industrial & garage door, powered gate & traffic barrier legislation TS 013-2:2021.

Compliance with this guide cannot confer immunity from legal obligations.

---

## Contents

Scope	3
1. Hazard identification control and compliance assessment	4
2. Structural integrity and vertically acting door fall-back safety	20
3. Electrical safety, control systems and safety devices	30
4. Safety distances, guards and enclosures	35
5. Hold to run (safety by human visual control)	40
6. Force limitation (safety by safe contact)	41
7. Non-contact presence detection	49
8. Lifting hazard control	55
9. Imprisonment hazard control	56
10. Manual doors & gates	56
11. Powered pedestrian gates	57
12. Reduced levels of safety for domestic garage doors	57
13. Residual risk assessment & control	58
14. Non-compliance	59
15. Fire resisting industrial doors (additional guidance)	64
16. Information and training	66

Revision	Description	Date
TS 011a & TS 012a	First edition	Apr 2019
TS 011a & TS 012a	Withdrawn	Jan 2022
TS 013-1:2021	First edition	Jan 2022

---

## Scope

This on-site guide contains guidance on the requirements for the safety of industrial doors, domestic garage doors, powered gates, and powered traffic barriers intended primarily for vehicles, but which could also be accessed by people.

This guide also covers vertically moving commercial doors, such as rolling shutters and grilles used in retail premises, which are mainly provided for the access of people rather than vehicles or goods.

It does not cover the following:

- 1) lock or dock gates (for boats)
- 2) lift doors
- 3) doors in vehicles
- 4) armoured doors (e.g. safe and strong room doors)
- 5) doors mainly intended to retain animals
- 6) theatre textile curtains
- 7) horizontally moving pedestrian doors & gates
- 8) railway crossing barriers (contact Network Rail)

The safety requirements described in this guidance apply to ordinary doors and fire/smoke resisting doors in equal measure.

The standards used to compile this guidance are:

- EN 12604:2000, 2017 & 2017+A1:2020 - manual systems
- EN 12453:2001, 2017 & 2017+A1 - powered systems
- EN 13241:2003+A2:2016 - product standard for Construction Products Regulations 2013

The standards referenced in this guide use a generic 'EN' prefix. Users are reminded however that, in the UK, these standards are published with a 'BS EN' prefix and, in the Republic of Ireland, an 'IS EN' prefix is used. The content and meaning are the same, however.

This guide is intended to guide installation and maintenance companies installing, maintaining and repairing systems on site.

Companies involved in serial manufacture or mass production are advised to use the relevant British/European standard.

This guide refers to and explains the sourcing and use of drive units, control systems and safety components but does not set out to guide manufacture of such systems.

## 1. Hazard identification

All doors, gates and barriers present potential hazards. Some hazards, like structural failure, electric shock and crush at the main closing edge, are generic to all systems, other hazards are system or site specific. Hazards are what could *potentially* cause harm. They are the things that *could* go wrong, and, hence, need to be prevented or controlled.

Hazard	Description
Building or foundation failure	Where the structure supporting the system fails
Fixing failure	Where fixings fail
Door/gate/barrier structure failure	Where the system structure fails
Wind load failure	Where wind load causes structural damage
Fall back of vertically acting doors	Where balancing systems fail
Electric shock/fire	Where electrical faults can cause harm
Control system failure	Where safety systems fail to function
Crush at the leading edge	Where the movement can compress a body
Crush, shear or draw-in at other moving parts	Where moving parts can compress body parts
Impact	Where horizontal movement can 'push' a body but without compressing it
Imprisonment	Where faults prevent exit

Missing or deficient safety systems or devices are not the hazard; they are a missing hazard control. Hazards exist regardless of controls but, where adequate controls are in place, the system becomes safe and compliant.

Hazards must be assessed in terms of the intended use of the system and foreseeable misuse of the system. This will include people walking through pedestrian entrances and riding on moving doors and gates where this is possible.

A further definition of moving parts hazards and example locations are shown over the page.

Reducing gap hazards can be further defined as follows.

Crush	Vertically reducing gaps below 2.5m Horizontally reducing gaps, 500mm or less
Impact	Where contact with horizontal movement occurs, in gaps greater than 500mm
Shear	The guillotine effect, commonly at gaps between sliding doors/gates and their supports
Draw-in	Where a body part is compressed into a gap, between sliding doors/gates and its supports or at the roll of shutters

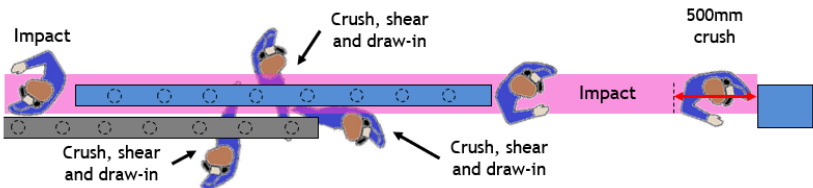
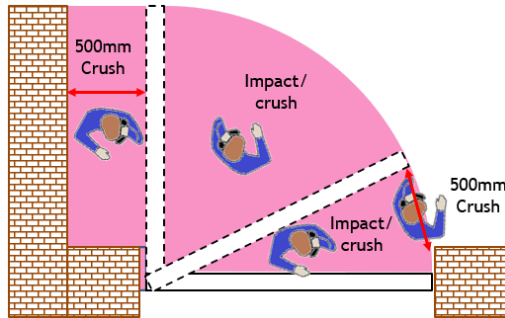
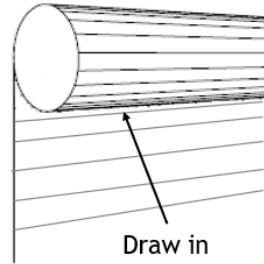
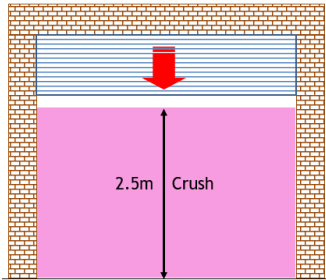

## 1.1. Common rolling shutter hazards

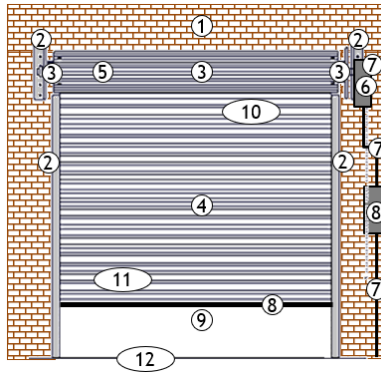

Hazard		Permitted minimum level of safety
1	Structural failure - supporting structures	Provide structural integrity
2	Structural failure - fixings	Provide structural integrity
3	Structural failure - shafts, plates, bearings, barrel, guides & travel stops	Provide structural integrity
4	Structural failure - wind load	Provide structural integrity
5	Fall-back - spring(s)	Provide fall-back protection
6	Fall-back - drive	Provide fall-back protection
7	Electrical - shock/fire	Provide electrical safety
8	Control - faults in safety systems	Provide control system integrity
9	Crush - closing, between 2.5m and the ground	Hold-to-run, force limitation, or non-contact presence detection
10	Draw-in - at the roll, when below 2.5m	Enclosure, hold-to-run, or non-contact presence detection
11	Lifting - people, where hand/foot holds exist	Limit hand/foot holds, limit force, hold-to-run, or non-contact presence detection
12	Imprisonment - of people	Provide manual release or alternative route

These are common significant hazards; other hazards routinely exist.

All hazards must be identified in the compliance assessment and then controlled in the same manner as those shown here.

## 1.2. Common sectional door hazards

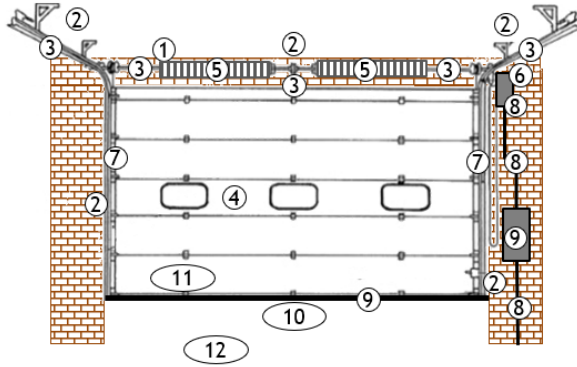

Hazard		Permitted minimum level of safety
1	Structural failure - supporting structures	Provide structural integrity
2	Structural failure - fixings	Provide structural integrity
3	Structural failure - shafts, plates, bearings, rollers, tracks, & travel stops	Provide structural integrity
4	Structural failure - wind load	Provide structural integrity
5	Fall-back - spring(s)	Provide fall-back protection
6	Fall-back - drive	Provide fall-back protection
7	Fall-back - cables	Provide fall-back protection
8	Electrical - shock/fire	Provide electrical safety
9	Control - faults in safety systems	Provide control system integrity
10	Crush - closing, between 2.5m and the ground	Hold-to-run, force limitation, or non-contact presence detection
11	Lifting - people, where hand/foot holds exist	Limit hand/foot holds, limit force, hold-to-run, or non-contact presence detection
12	Imprisonment - of people	Provide manual release or alternative route

These are common significant hazards; other hazards routinely exist.

All hazards must be identified in the compliance assessment and then controlled in the same manner as those shown here.

### 1.3. Common sliding door/gate hazards

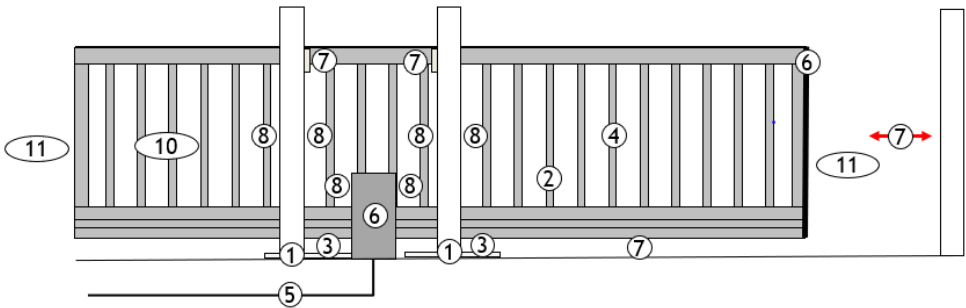

Hazard		Permitted minimum level of safety
1	Structural failure - supporting structures	Provide structural integrity
2	Structural failure - leaf	Provide structural integrity
3	Structural failure - guides, rolling gear & travel stops	Provide structural integrity
4	Structural failure - wind load	Provide structural integrity
5	Electrical - shock/fire	Provide electrical safety
6	Control - faults in safety systems	Provide control system integrity
7	Crush - reducing gap, less than 500mm (open/close)	Safety distance, hold to run, force limitation or non-contact presence detection
8	Shear & draw-in - at the supports, drive or other fixed objects	Enclosure, hold to run, safe edge or non-contact presence detection
9	Crush - at guide rollers	Enclosure, hold to run or non-contact presence detection
10	Shear - through perimeter fence	Enclosure, hold to run, or non-contact presence detection
11	Impact - swept area	Enclosure, hold to run, force limitation, or non-contact presence detection

These are common significant hazards; other hazards routinely exist.

All hazards must be identified in the compliance assessment and then controlled in the same manner as those shown here.

## 1.4. Common hinged door/gate hazards

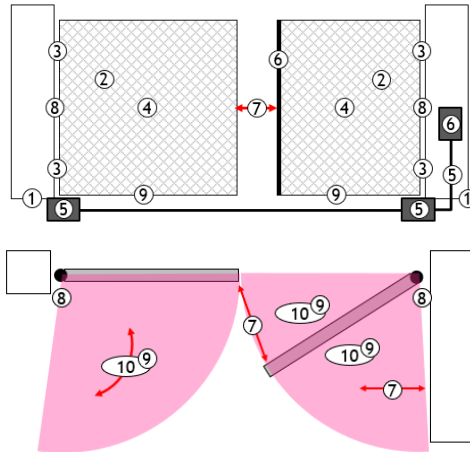

Hazard		Permitted minimum level of safety
1	Structural failure - supporting structures	Provide structural integrity
2	Structural failure - leaf	Provide structural integrity
3	Structural failure - hinges, fixings & travel stops	Provide structural integrity
4	Structural failure - wind load	Provide structural integrity
5	Electrical - shock/fire	Provide electrical safety
6	Control - faults in safety systems	Provide control system integrity
7	Crush - reducing gap, less than 500mm (open/close)	Safety distance, hold to run, force limitation or non-contact presence detection
8	Crush - hinge area	Safety distance, flexible guard, hold to run, safe edge or non-contact presence detection
9	Crush - under door/gate	Safety distance, hold to run, force limitation, or non-contact presence detection
10	Impact - swept area	Hold to run, force limitation, or non-contact presence detection

These are common significant hazards; other hazards routinely exist.

All hazards must be identified in the compliance assessment and then controlled in the same manner as those shown here.

## 1.5. Common folding door/gate hazards

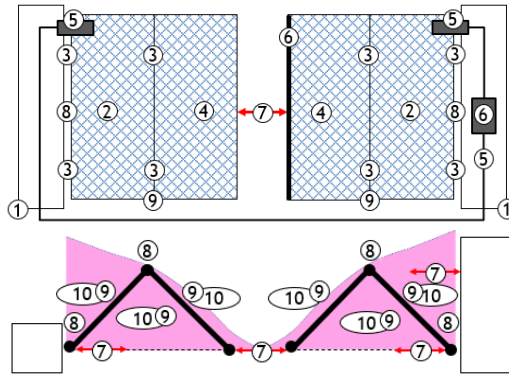

Hazard		Permitted minimum level of safety
1	Structural failure - supporting structures	Provide structural integrity
2	Structural failure - leaf	Provide structural integrity
3	Structural failure - hinges, fixings & travel stops	Provide structural integrity
4	Structural failure - wind load	Provide structural integrity
5	Electrical - shock/fire	Provide electrical safety
6	Control - faults in safety systems	Provide control system integrity
7	Crush - reducing gap, less than 500mm (open/close)	Safety distance, hold to run, force limitation or non-contact presence detection
8	Crush - hinge area	Safety distance, flexible guard, hold to run, safe edge or non-contact presence detection
9	Crush - under door/gate	Safety distance, hold to run, force limitation, or non-contact presence detection
10	Impact - swept area	Hold to run, force limitation, or non-contact presence detection

These are common significant hazards; other hazards routinely exist.

All hazards must be identified in the compliance assessment and then controlled in the same manner as those shown here.

## 1.6. Common traffic barrier hazards

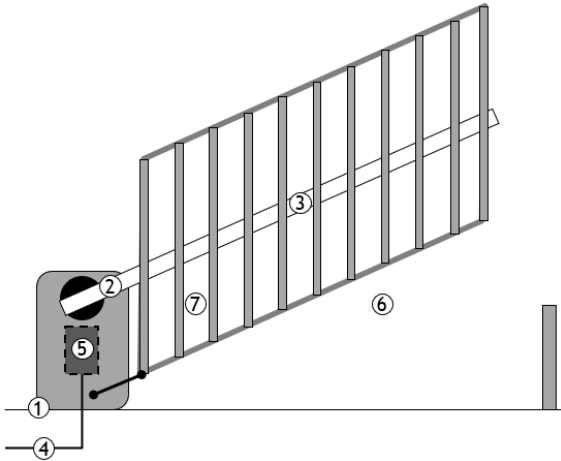

Hazard		Permitted minimum level of safety
1	Structural failure - supporting structures	Provide structural integrity
2	Structural failure - arm, pivots and fixings	Provide structural integrity
3	Structural failure - wind load	Provide structural integrity
4	Electrical - shock/fire	Provide structural integrity
5	Control - faults in safety systems	Provide control system integrity
6	Crush - under arm, or lower rail of a linked skirt	Safety distance, hold to run, force limitation or non-contact presence detection
7	Crush - at verticals and linkage of linked skirt	Safety distance, flexible guard, hold to run, safe edge or non-contact presence detection

**NOTE:** A free hanging, lightweight, gravity deployed skirt does not normally present a significant crush hazard but, once the skirt has collapsed on contact, the barrier arm does!

These are common significant hazards; other hazards routinely exist.

All hazards must be identified in the compliance assessment and then controlled in the same manner as those shown here.

---

## 1.7. Hazard control

The minimum level of safety deemed acceptable by health and safety legislation is described variously as the ‘state-of-the-art’ or “reasonably practicable” precautions, depending on the exact environment and jurisdiction. In either case, this is the level of safety described in product specific standards:

- EN 12604 - structural strength - manual vehicle access doors, gates & barriers
- EN 12453 - powered industrial & garage doors, vehicle gates & barriers
- EN 12978 - sensitive safety devices for powered doors, gates & barriers

These ‘state-of-the-art’ standards permit four main strategies for controlling hazards:

- 1) Safe design (structural integrity, elimination of hazards, guards, electrical & control system integrity) - always the 1st priority
- 2) Human visual control (hold-to-run)
- 3) Safe contact (force limitation)
- 4) Non-contact (presence detection that prevents hazardous contact)

The term ‘state-of-the-art’ has various meanings in differing environments. In this environment, it is not ‘cutting edge’ or ‘best possible’, it is simply the level of safety described in the current standard.

Systems should be designed to eliminate or reduce hazards by safe design wherever possible, rather than use sensitive devices to control hazards created by the design. Hazards that cannot be eliminated or reduced by safe design should be controlled by one or a combination of the remaining three options.

Hazard controls must be put in place for intended use hazards and foreseeable misuse hazards.

---

## 1.8. Compliance assessment process and recording

Installation and maintenance companies should conduct and record a compliance assessment and retain it as evidence of due diligence:

- 1) for new installations
- 2) prior to taking on reactive or planned maintenance of a system for the first time
- 3) upon modification of an existing system

Ongoing routine maintenance should include safety checks to ensure that the system is still safe, but it should not be necessary to fully re-document the entire compliance assessment at every visit.

The assessment must consider hazards caused by normal or use, and foreseeable misuse of the system. Foreseeable misuse includes people walking through or under vehicle entrances or riding on systems, regardless of any signage present.

Where the compliance assessment for installation of a new UKCA/CE marked system, supplied by a third-party, indicates that it does not achieve the state-of-the-art, the installation company should refer to and apply the process described in **DHF TS 013-2:2021** (legislation guide). Where the assessment of such a system indicates that the state-of-the-art is achieved but residual hazards are present, based on its local environment or use, the installation company should address them. A fully documented compliance assessment should include the following seven steps:

### Step 1 – Describe the site, environment, nature of users and the system

Describe the system, the nature of users, the environment, the activation methods and the expected duty cycle, etc.

### Step 2 – Make a hazard list

Make a list of all hazards associated with the system: structural, electrical, control or safety system, moving parts, wear and tear, etc. This part is simply a list of all the things that could present a hazard in normal use and under foreseeable misuse. This section should not be confused with describing specific ‘faults’ with a given system; it is a list of potential hazards that must be controlled.

### Step 3 – Resolve as many hazards as possible by application of, or checking for, safe design

Provide (or propose for existing systems) measures to resolve or reduce as many of the hazards listed in step 2 as possible by improving the design to eliminate or reduce the hazard. These will include structural integrity, safe distances and clearances, guards & enclosures, electrical safety, and control/safety system integrity.

### Step 4 – Resolve the remaining hazards by application of, or checking for, state-of-the-art control measures

Provide (or propose for existing systems) permitted measures to control all remaining hazards: hold-to-run, inherent force limitation, safe edge force limitation, non-contact presence detection. In all cases, the state-of-the-art standards represent the absolute minimum acceptable level of safety needed for legal compliance.

---

### Step 5 – Residual risk assessment

Identify and list the residual hazards (hazards that remain when the state-of-the-art is achieved). Consider the risk to vulnerable users, e.g. high numbers of children, persons with mobility, sight, hearing, learning limitations. Protection of vehicles should also be considered at this stage; the state-of-the-art is mainly focused on the safety of people.

### Step 6 – Provide appropriate residual risk controls

Provide (or propose for existing systems) residual hazard control measures based on the likelihood of occurrence, frequency of occurrence and user vulnerability. If necessary, consider reducing some hazards further, e.g. by proposing even lower force, additional photo beams, non-contact technology or re-design.

Residual hazard controls include things like warning lights, markings, signage and other pedestrian or traffic control systems.

### Step 7 – Provide/review the operation and maintenance (O&M) manual

Provide (or assess the existing) operation, maintenance manual (O&M).

The user section should identify and explain the residual hazards. Safe use instructions should explain how to use the system and specify any user training necessary. There should also be a section that explains how the safety systems function, how to identify a fault and what to do/not do, including how to isolate the system and use it in manual.

The maintenance section should explain the steps necessary to keep the system in a safe condition. For example, the inspections, cleaning, lubrication, adjustment, routine parts replacements, and safety testing necessary. The manual should also describe the frequency, skills, qualification and experience necessary for each task.

*A compliance assessment flow diagram is over the page. →*

### 1.8.1. Compliance assessment process flow diagram

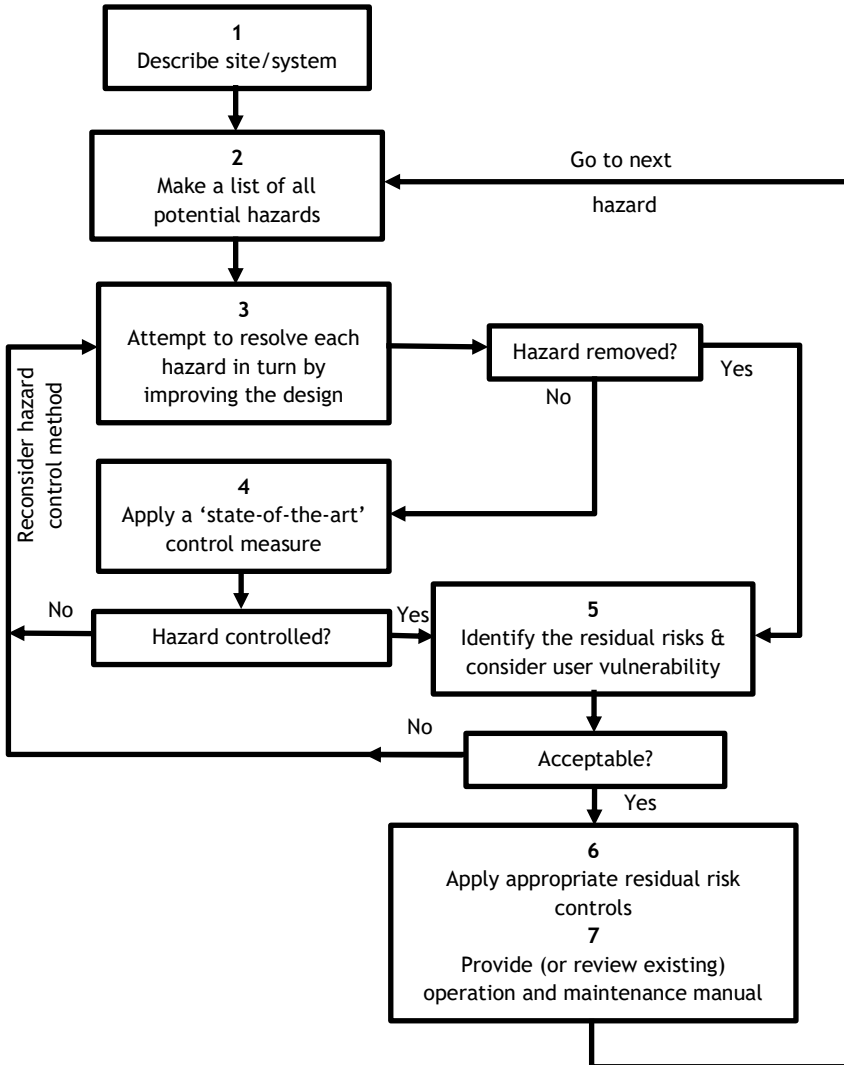

## 1.8.2. Example compliance assessment document

### **Doors-R-Us Discovery Park, Oldville, OL3 14TR**

**info@doorsrus.com.uk – 01234 567 890 - doorsrus.com.uk**

#### Compliance Assessment

Job reference: **NT1 2TN - call out**

Site address: **A Daley MOT, Unit 1, Trading Estate, Newtown.**

Postcode: **NT1 2TN**

Assessment conducted by: **Fred Bloggs**

~~N/A New~~  ~~Reactive repair~~ ~~N/A Planned maintenance~~ ~~N/A Modification~~

~~N/A Rolling shutter~~ ~~N/A Sectional~~ ~~N/A Folding~~ ~~N/A High speed~~ ~~N/A Sliding~~

Other: **N/A**

Number of leaves: **1** Leaf 1 width: **3.5m** Leaf 2 width: **N/A**

Material: **Galvanised steel** Height: **3.5m** Weight: **550kg**

Percentage infill: **100%** Expected operations per day: **30**

#### **Weather conditions:**

What weather conditions will the door be exposed to?

~~N/A Inside location~~  ~~Outside location~~  ~~Sheltered~~ ~~N/A Exposed~~

Estimated maximum wind gust speed: **70mph**

Other: **N/A**

#### **Users and others who may encounter the door:**

~~N/A No untrained persons present~~  ~~Untrained persons could be present~~

~~N/A High numbers of vulnerable persons present~~

Nature of vulnerable persons: **N/A**

Reason/location for vulnerable persons: **N/A**

No.	Hazard description and location
1	Failure of the building structure supporting the door
2	Door fixing failure
3	Barrel, shaft, end plate, curtain or bearing failure
4	Fall-back due to drive unit failure
5	Structural failure due to wind load
6	Electrical faults causing shock or fire
7	Control system faults causing loss of safety
8	Crush at the main edge
9	
10	
11	
12	

	Hazard control measure applied/ <del>proposed</del>
1	Door structure bolted to steel plates welded to building steel frame, guides fixed to masonry infill with expanding bolts - all appear sound with no sign of stress or movement.
2	4 x m12 bolts on each end plate, 6 x m8 masonry fixes on each guide - all secure with no sign of movement, despite the impact damage that initiated this RA.
3	End plates, shafts, barrel and curtain attachments all appear sound and secure, large washers on curtain attachment - 1 whole wrap remains on the barrel at fully closed.
4	GGs 2014 centrifugal safety brake installed - rating and rotation direction correct.
5	18g lath and 75mm guides, door judged to be class 4 by experience, this would appear to be adequate, no reports of historic wind damage from client, damaged lath replaced like for like.
6	Supply covered by client periodic reports, system wiring suitable specification and in good condition.
7	XYZ tube motor & ABC control panel, on board radio safe edge system, DEF 65mm safe edge - all appear in good condition compatible and functioning.
8	Crush forces measured, less than 200N, 0.5s to below 150N, 0N within 5s - perfect. Internal photo beam at 300mm fully functional.
9	
10	
11	
12	

	Residual risk description	Residual risk control measure proposed
1	Door closing on a person, general public are present in high numbers.	External beam at 1200mm and external auto door sign.
2	Door closing on a vehicle.	As above.
3	Vehicle impacting door - the reason for this call out.	Hazard tape on lower edge and internal traffic light.
4	Users not aware of how to use the manual chain.	User instruction on wall by the controls.
5	Client does not have O&M manual.	O&M manual.
6	Door will become dangerous if not regularly maintained.	O&M manual.
7		
8		
9		

N/A ~~User warnings and instructions suitable~~

N/A ~~Maintenance instructions suitable~~

Notes: A Certificate of compliance cannot be issued until the residual hazard control measures are agreed with the client and put in place.

Signature: Fred Bloggs Date: 12/2/2021

## 2. Structural integrity

The supporting structure and the door, gate or barrier should be capable of resisting falling down, collapsing, or derailment, in normal use and under foreseeable misuse conditions.

The responsibility for initial assessment of a building's ability to support a new door or gate is a job for an architect, principal designer, or surveyor.

Structural alterations should not be made to existing fire resisting shutters, unless the modification has been approved (in writing) by the manufacturer. Such alterations can change how the shutter will perform under fire conditions, and negate any certification provided by the manufacturer - see also 2.3.6.

### 2.1. Structural strength

The prescribed design safety factors, according to EN 12604, are as follows:

- 1) 2 x total foreseeable load without permanent or detrimental deformity
- 2) 3.5 x total foreseeable load without ultimate structural failure.

As these are the design safety factors required, any on-site testing at these levels could seriously damage a system. The safety factors quoted in 1 & 2 above should be used as an informative 'indicator' of the levels of structural strength necessary when making a visual assessment of existing systems under maintenance.

#### 2.1.1. Fixings

Fixings used to attach door, gate or barrier systems to their supporting structures or foundations should be assessed against the fixing manufacturer's rating data, the system loadings and the materials being fixed to.

#### 2.1.2. Travel stops

Travel stops should be provided to prevent derailment, both in normal use and when used manually; manual use is likely to generate the greatest loadings.

It should be possible to secure hinged systems against wind action in the fully open and fully closed position when used in manual.

**NOTE:** *A travel stop sited close to a hinge can lead to extreme loadings at the hinge, particularly when used in manual or when subject to high winds.*

#### 2.1.3. Hinges and other suspension elements

Suspension elements must be designed such that falling over, collapse or derailment is prevented in normal use, upon encountering an obstacle, and in the event of failure of one of the suspension elements; this was relaxed to some degree for hinged systems in 2018 (see 2.1.3).

#### 2.1.4. Post 2018 hinged systems

Since 2018 (post publication of EN 12604:2017), if a hinge fails:

- 1) the leaf is permitted to fall a maximum of 300mm off vertical

*Continues →*

- 2) should be protected against being lifted more than 50% of the hinge pin length.

This relaxation of the rules allows the use of catch straps or safety lanyards, which will also be useful when upgrading existing systems of uncertain structural integrity.

#### 2.1.5. Door curtain attachments

Rolling shutter curtain attachments should be secured against normal loads and shock loads (e.g. safety brake engagement). EN 12604 suggests at least 50% of the barrel be covered at fully closed; many manufacturers prefer 100%. DHF suggests the use of large diameter washers to prevent pull through of bolt heads where slotted holes are used in the top lath to permit lateral adjustment.

#### 2.1.6. Barrel/shaft retention and alignment

Barrels, shafts, drive gears, drive chains, bearings, guide tracks, wheels and rope drums should be positively aligned and secured such that detrimental movement, misalignment or disengagement is prevented. This can be achieved in a variety of ways depending on the design: bolts in shaft ends, split pins and washers, collars, grub screws on steel keys, and end plate bracing. Every system must be assessed on its merit, secure alignment should not rely on friction alone.

#### 2.1.7. Steel wire rope

Where a leaf is suspended on wire ropes, there should be at least two ropes and the load should be shared equally. The ropes should have a safety factor of at least 6 x load, regardless of any additional rope break protection that might be necessary to limit the drop (see 2.3).

Pulleys and drums should have a pitch circle diameter (PCD) of at least 20 x rope diameter, unless the rope maker certifies the rope on a smaller PCD. Drums should be grooved to keep the rope in one layer, pulleys should prevent jumping out or derailing and it should be possible to inspect the entire rope length for maintenance.

Rope terminations should achieve a safety factor of at least 6 x load (e.g. properly swaged fittings) or have at least two turns of rope remaining on the drum when fully extended (e.g. where screw terminations are used).

#### 2.1.8. Resistance to wind load

The structural assessment should take account of wind load. The system should remain safe when subject to foreseeable wind loadings. A system is not necessarily required to remain functional in high winds (although client/contractual requirements might require otherwise); the system should, however, remain safe. We offer the following advice in terms of likely maximum wind gust speeds:

- 1) 50 mph = sheltered (inner-city, built-up areas with close buildings on all sides)
- 2) 70 mph = normal (normal urban environments)
- 3) 100 mph = exposed (open, rural, hilltop or coastal environments).

Actual wind pressures are not reliant on wind speed. Other factors including atmospheric pressure, altitude and surrounding hills and buildings have a significant effect.

Door or gate infill percentage and infill shape also affect wind load.

**NOTE:** *Gates and doors with more than 30% infill will generate considerable wind resistance and should be constructed accordingly, with more attention paid to the integrity of foundations, supports, fixings, hinges, posts, and leaf structure, etc.*

### 2.1.9. Resistance to wind load type test evidence

Since July 2013, the Construction Products Regulations (CPR) has required that, before new doors within the scope of EN 13241 are placed on the market, they must be type tested for resistance to wind load (amongst other characteristics) according to that standard.

The door must bear a UKCA/CE label or plate that explains: the manufacturer's name & address, the wind load class, the approved (notified) test body used, and the designated (harmonised) standard used.

<b>COMPANY NAME</b>		<b>COMPANY ADDRESS</b>	
CE or UKCA + year of manufacture		<b>PRODUCT DESCRIPTION</b>	
		<b>SERIAL OR MODEL NUMBER</b>	
<b>Essential Characteristics</b>		<b>Performance</b>	<b>Standard</b>
Dangerous substances		NONE	<b>EN 13241</b>
<b>RESISTANCE TO WIND LOAD</b>		<b>CLASS (0-5)</b>	
Safe opening		PASS	
Definition of geometry of glazing		PASS	
Mechanical resistance and stability		PASS	
Operating forces		PASS	
Type testing by:	<b>APPROVED/NOTIFIED BODY REFERENCE NUMBER</b>		
Intended use:	<b>DESCRIPTION</b>		

*The items in red italics are the critical information for wind load*

If a label bearing the required information is not evident or has been obliterated, the owner or manager may be in possession of the manufacturer's Declaration of Performance which should also bear the required information. If a Declaration of Performance is not held, it may be possible to obtain a copy from the door manufacturer. EN 13241 requires that wind load calculation or testing is conducted according to EN 12444, and the results should be classified using EN 12424 as follows below.

Class	Performance	Class	Performance
0	No performance determined	3	700 pascals <i>(maybe around 75 mph gust)</i>
1	300 Pascals <i>(maybe around 50 mph gust)</i>	4	1000 Pascals <i>(maybe around 90 mph gust)</i>
2	450 Pascals <i>(maybe around 60 mph gust)</i>	5	Anything over 1000 Pascals, the actual rating in Pascals must be declared.

*Resistance to wind load classifications*

*Continues →*

The absolute minimum requirement for a door on an external wall is class 2.

However, a door for a given location should be specified to withstand its reasonably expected environmental conditions without compromising safety; it is not possible to simply resort to class 2.

The classes are in Pascals and relate to the pressure differential rather than actual wind speed. Relating this to actual real-world gusting wind speed is complex. Information on predicting actual wind pressures in Pascals on buildings can be found in BS 6375-1 or, more accurately, in BS EN 1991-1-4. Door manufacturers are only required to declare the wind class of their door in Pascals, they are not required to specify the required wind class for a particular location.

The required wind class for door at a specific location should be declared by the client or their principal designer/architect. In the absence of a specification in Pascals from the client, the door supplier should take great care when specifying a suitable door. The client may be expecting that the door company is acting as the principal designer!

**NOTE:** *In an attempt to illustrate real world conditions, the table (previous page) includes a DHF estimate of the gust speeds that might generate the various loadings in bracketed italics. This cannot be seen to be categorical!*

Actual peak gust figures on site are regularly much higher than those declared in weather forecasts by a considerable margin!

## **2.2. Vertically acting door fall-back safety**

Vertically moving door leaves should achieve static balance such that they remain static in the fully open and fully closed position.

Static balance is commonly achieved by use of non-reversing gearboxes (with or without drive chains/gears), springs, counter-balance weights, cables or hydraulic valving.

### **2.2.1. Vertically acting door fall-back protection**

Vertically moving door leaves should be protected against falling back due to a fault or failure in the balancing system.

### **2.2.2. Fall back protection – low static weight**

Fall back protection can be disregarded where the effective static weight of the door, following any single vulnerable component failure, is less than 20kg. For example, 38kg door with two springs = 19kg with one spring failed.

### **2.2.3. Use of low static weight post 2021**

Once EN 12453:2017+A1:2021 has achieved designated (harmonised) status, manufacturers will only be able to rely on the low static weight relaxation (20kg), where the failed component is clearly visible or detectable to users.

#### 2.2.4. All other vertically acting doors

Some components within the balancing system can be considered resistant to failure, provided they achieve the design strength safety factors (see 2.1). Other more vulnerable components, subject to wear and fatigue, require a backup system or device.

Components that can rely on strength alone include:

- 1) supporting structures & fixings
- 2) panels & lath sections and their quirks or hinges
- 3) guides, rollers & tracks
- 4) shafts, barrels, bearings & key steels.

Vulnerable components that should be provided with a backup system or device, regardless of strength include:

- 5) springs, counterweight cables, suspension cables or chains
- 6) hydraulic hoses and rams
- 7) drive unit gearboxes, drive chains, and drive gears.

Fall-back protection can be achieved by an inherently safe design system (e.g. spring & gearbox combinations with force sensing systems to prevent further use) or by using safety devices. A functional motor brake used to control stopping and overtravel in normal use cannot be used as fall-back protection. Fall back protection must be effective, even when the manual override is used.

At the point of failure of any one single vulnerable component, the door leaf should:

- 8) not drop more than 300mm (when within 2.5m of the ground), and
- 9) be held securely in position, or
- 10) powered doors are permitted to continue closing, under full control and at normal operating speed, providing they are prevented from further use after that.

Activation of the fall-back protection should not cause any secondary failures and the remaining components should be able to bear all resulting dynamic and static loads safely.

Fall-back protection devices are classified as safety components by the terms of the Supply of Machinery (Safety) Regulations (Machinery Directive). Installation and maintenance companies should only use correctly specified devices that are supplied with a manufacturer's machinery Declaration of Conformity and installation instructions, which should be followed.

If a fall-back protection device manufacturer requires that the device has a stop switch connected when used on a powered door, the switch should be used because, without it, the protection offered by the device manufacturers declaration of conformity is lost.

Consideration must also be given to preventing further use of the door following failure such that:

*Continues →*

- 11) the door stops immediately, or
- 12) the door continues to the fully closed position under full control and at normal operating speed, and is then prevented from further use, or
- 13) a trained user operating a manual or hold-to-run door could reasonably be expected to notice the failed component.

The door's O&M manual should explain how to identify when a fall-back protection has engaged, and what the user should do in response. *The manual will need to explain very clearly what the effect will be, what to do, and what to check.*

**NOTE:** *'Prevention of further use' where protection is provided by inherent design rather than by use of a device, was not well explained in the original 2000 version or the 2017 revision of EN 12604. It does though make good sense; without this, a system could continue in use following a critical component failure and the door could become lethal.*

*Death incidents and subsequent prosecutions have reinforced the need to prevent further use following a failure.*

### 2.2.5. Fall-back protection type test evidence (safe opening)

Since July 2013, the Construction Products Regulations (CPR) have required that, before new doors are placed on the market, they must be type tested for fall-back protection (amongst other characteristics) and bear a UKCA/CE label or plate that explains the following information: the manufacturer's name & address, SAFE OPENING - PASS, the approved (notified) test body used, and the designated (harmonised) standard used.

<b><i>COMPANY NAME</i></b>		<b><i>COMPANY ADDRESS</i></b>	
CE or UKCA + year of manufacture		<b><i>PRODUCT DESCRIPTION</i></b>	
		<b><i>SERIAL OR MODEL NUMBER</i></b>	
<b>Essential Characteristics</b>		<b>Performance</b>	<b>Standard</b>
Dangerous substances		NONE	<b><i>EN 13241</i></b>
Resistance to wind load		CLASS (0-5)	
<b><i>SAFE OPENING</i></b>		<b><i>PASS</i></b>	
Definition of geometry of glazing		PASS	
Mechanical resistance and stability		PASS	
Operating forces		PASS	
<b>Type testing by:</b>	<b><i>APPROVED/NOTIFIED BODY REFERENCE NUMBER</i></b>		
<b>Intended use:</b>	<b><i>Description</i></b>		

*The items in red italics are the critical information for safe opening*

If a label bearing the required information is not evident, or has been obliterated, the owner or manager may be in possession of the Declaration of Performance which should also bear the required information. If a Declaration of Performance is not held, it may be possible to obtain a copy from the door manufacturer.

Where a Declaration of Performance or UKCA/CE label bearing the required information is available, and it can be confirmed that the door has not been modified since manufacture, it is normally safe to assume that fall-back protection is adequate, unless there are obvious deficiencies.

### 2.2.6. Assessing fall-back protection on existing vertically acting doors

Where the door is not correctly UKCA/CE marked, or the manufacturer's Declaration of Performance is not available, it may not be easy to tell if a particular door in service has adequate fall-back protection. To assist with this, the following guidance is offered for doors with an out of balance static weight of more than 20kg (see 2.2.2 & 2.2.3).

**Step 1** - Identify which *vulnerable* components (see 2.2.4) hold the door open.

**Step 2** - Consider each vulnerable component one at a time, in isolation; assess what will happen if the component fails, for example:

#### 1. Door drops out of control (safety critical) - not OK

- e.g. - tube motor operated unbalanced shutter, or manual balanced sectional door without spring break devices

#### 2. Door drops but is caught by a device and prevented from further use ✓

- e.g. - unbalanced shutter driven by a direct drive with internal protection

#### 3. Door drops slightly and the drive is switched off ✓

- e.g. - sectional door with slack cable stop switches

#### 4. Door jams and the drive continues to run (requires improvement) - not OK

- e.g. - impulse open/close sectional door, with unlimited torque drive and no spring break or cable slack stop switches

#### 5. Door is supported by another component and is prevented from further use ✓

- e.g. - balanced shutter with torque limited tube motor

#### 6. Door continues to operate normally (requires improvement) - not OK

- e.g. - spring balanced shutter with unlimited torque drive

#### 7. Door drops slightly and jams, the trained user can see the failed cable and stops the door ✓

- e.g. hold-to-run open/close sectional door without slack cable devices or switches

As each component failure assessment is completed, assume it is then restored before moving on to consider the next *vulnerable* component. When any part of this is not known, for example, motor torque or spring balance, the door is rated as requiring further investigation, see 2.2.8.

Retractable and canopy doors can be treated as sectional doors. Vertically acting door types not specifically covered here should be treated in a similar manner. *Continues →*

Unbalanced doors need a safety brake or an internally protected direct drive unless they conform to 2.2.2.

There are minor relaxations for some permanently held open fire doors, see 2.2.7.

Spring balanced shutters and sectional doors are a little more complex to assess. The following flow charts may prove helpful where a safety brake, spring break device or direct drive with internal protection is not fitted.

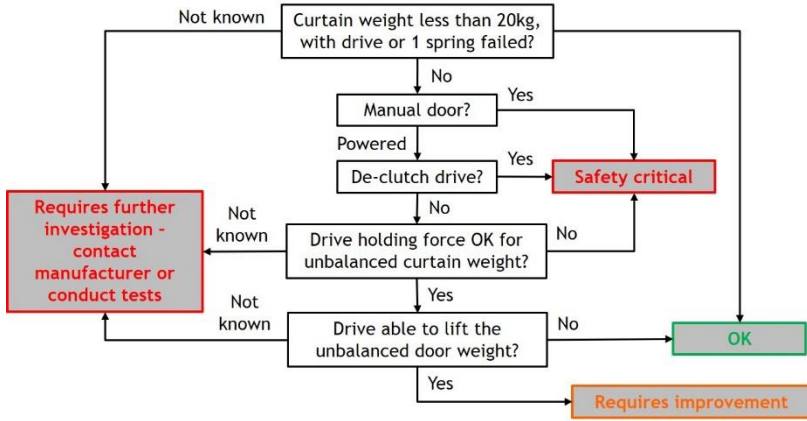

*Spring balanced doors without protection or correct UKCA/CE marking*

Where cable slack jamming devices are not installed on a sectional door, the following flow chart may prove helpful.

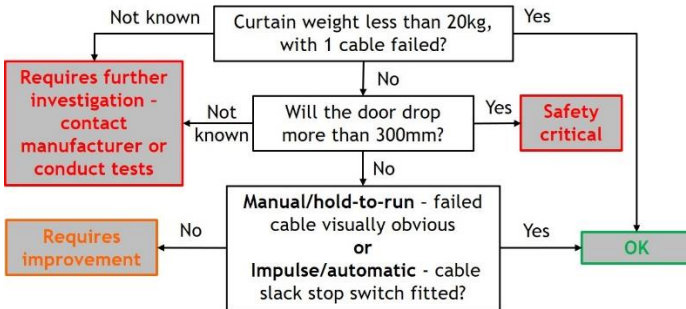

*Sectional doors without slack cable jamming devices or correct UKCA/CE marking*

**Safety critical** = cannot be left in service

**Requiring improvement** = could be left in service but only where the client has been made aware of the risks and requests the door to be left in service (traceably)

**Requiring improvement** is neither safe nor compliant, it simply means not immediately lethal

Hydraulic doors should be protected from fall-back due to hydraulic failure by internal valving. Check with the manufacturer where doubt exists.

Doors that are balanced by counterbalance weights and cables need slack cable protection such that any one cable failure will be detected, prevent fall-back, and prevent further use.

The following table offers further guidance on the minimum levels of protection required on a range of door configurations where the out of balance static weight is above 20kg (see 2.2.2).

Door type	Possible failures	Minimum protection	Result when not present
Manual shutter with single spring	Spring	Safety brake	<b>Safety critical</b>
Manual shutter with dual springs	Spring	Calculate curtain weight: – Less than 40kg = OK – More than 40kg = not OK	<b>Safety critical</b>
Unbalanced tube motor shutter	Gearbox	Safety brake	<b>Safety critical</b>
Balanced tube motor shutter	Spring Gearbox	Torque limited drive (unable to lift the door following spring failure)	<b>Requiring improvement</b>
Unbalanced shutter with direct drive	Gearbox	Internal gearbox protection	<b>Safety critical</b>
Balanced shutter with chain or gear drive	Spring Drive chain Drive gear Gearbox	Torque limited drive (unable to lift the door following spring failure)	<b>Requiring improvement</b>
Manual balanced sectional	Spring Cable	Spring break devices, or (with test evidence) just slack cable jamming devices	<b>Safety critical</b>
Powered sectional with direct drive	Spring Gearbox Cable	Torque limited drive Cable slack stop switches if not HTR open & close	<b>Requiring improvement</b>
Powered sectional with de-clutch drive	Spring Gearbox Cable	1) Spring break devices, or (with test evidence) just cable slack devices 2) Cable slack stop switches if not HTR open & close	<b>Safety critical</b> <b>Requiring improvement</b>

*Minimum levels of protection on common door configurations*

---

### 2.2.7. Fire/smoke resisting door fall-back protection

New fire and smoke resisting doors are subject to the same requirements for safety as any other door in normal day-to-day use, including fall-back protection. EN 12604 (manual doors) and EN 12453 (powered doors) have required fall-back protection since 2000. This, together with machinery and workplace legislation, means that there has always been a need to prevent a catastrophic fall-back in the event of a simple fault.

Some existing manually operated, spring balanced fire shutters that are permanently held open and only close under fire conditions, but do not have fall back protection, can be rated as **'requiring improvement'** on the basis that their very infrequent use places them at a much-reduced risk of falling back.

There is however a risk of false deployment based on a fault in the deployment system. More attention should be given to inspection and maintenance, in particular, regular replacement of fusible links in line with the link manufacturer's specification.

**It is not possible to simply replace a plain bearing with a safety brake on a fire resisting shutter. Such an alteration could alter the shutter's ability to resist fire and negate any certification offered by the manufacturer. If such an alteration is to proceed, it must be sanctioned by the manufacturer, in writing (see section 2).**

### 2.2.8. Requiring further investigation

Where an initial assessment of an existing door reveals that it is requiring further investigation, this could mean one or more of the following:

- 1) contacting the manufacturer for evidence of conformity (e.g. DOP)
- 2) dismantling and safely conducting tests on site, to establish for example:
  - the static weight following component failure, or
  - if the door is in fact balanced, or
  - if the drive could lift the curtain following spring failure, or
  - the degree of drop following cable failure.
- 3) calculations to reveal things like curtain weight, turning moment and motor torque required to move the unbalanced door (e.g. following spring failure).

Where there is serious doubt, and no test evidence exists, it may in some circumstances be better to recommend the installation of devices as a precaution because some testing could in fact be destructive.

**NOTE: This does not imply in any way that the maintenance company should cover the cost of investigation work. This would normally be a matter in the terms of the maintenance contract.**

### 3. Electrical safety

Electricity at work legislation requires that work on electrical systems should be conducted by an electrically skilled person (e.g. a qualified electrician).

Alternatively, some work can be conducted by someone who is following competent guidance as follows:

- 1) an installer following the product's installation manual, or
- 2) an installer who has been trained to install the product in question, or
- 3) by receiving direct supervision on site from an electrically skilled person.

This does not make the installer an electrically skilled person, only skilled enough to execute a specific task.

#### 3.1. Safe isolation

A means to safely electrically isolate line (live) and neutral from the system for maintenance should be provided (single phase = double pole & 3 phase = 4 pole). Where an electrical isolator is remote from the system (cannot be seen from the place of work), it should be labelled and be possible to secure it in the off position. Acceptable methods of providing isolation are multi pole switches or plug and socket combinations.

Safe isolation practices should be applied whenever possible when working on electrical equipment; any live work that is necessary should be conducted with extreme care and using appropriate precautions and equipment.

#### 3.2. Supply wiring

The fixed wiring electrical supply to the installation should be provided, tested, and certified, to comply with BS 7671/ET 101 (current version). Where an existing supply is utilised for an installation, evidence should be gained to demonstrate that it has been tested to ensure safety and compliance with BS 7671/ET 101 (e.g. client Electrical Installation Certificate or Periodic Inspection Report copy).

#### 3.3. System wiring

The control panel/motor manufacturer's installation manual should take precedence in this regard. Where cable specifications and installation methods are prescribed in the manual, they should be followed.

Where the control panel/motor manufacturer prescribes the use of an RCD in the supply circuit, the specified device should be present upstream of the installation.

Where no training or installation manual is available, the principles outlined in EN 60204-1 as amended by EN 12453 should be applied by an electrically skilled person.

#### 3.4. Conductive parts earthing

The control panel/motor manufacturer's installation manual should take precedence. Where the earthing requirements are prescribed in the manual, they should be followed. Where no installation manual is available, advice should be sought from an electrically skilled person (e.g. qualified electrician).

*Continues →*

International earthing symbols are show below.



Class 2 double insulated  
equipment - do not earth!



Class 1 equipment - must be  
earthed!

### 3.5. Electrical enclosures

Enclosures subject to external conditions should be at least IP54 (to prevent insect or slug ingress).

Enclosures and drive units used below ground should be at least IP67. As IP67 only covers temporary immersion, where IP67 components are used underground, effective drainage should be provided.

Enclosures containing exposed dangerous voltages (55v or more) should be marked with an appropriate dangerous voltage label and only be openable by means of key or tool.

### 3.6. Mechanical protection of cables

All vulnerable fixed cabling should be provided with mechanical protection by means of conduits, trunking or armouring. Vulnerable cabling is anything containing 55v or greater, or anything that forms part of a control system. Examples include photo beam cables, safe edge cables, non-contact presence detection cables, motor cables, encoder cables or access control device cables. Flexible cable loops at drives and curly cables used on vertically acting doors do not need protection, providing 3.7 and 3.8 are met.

### 3.7. Control system integrity

Drive units and control panel combinations are classified as partly complete machines by the terms of the Supply of Machinery (Safety) Regulations (Machinery Directive). Installation and maintenance companies should only use appropriate door, gate or barrier specific control panel and drive unit combinations that are supplied with the manufacturer's machinery Declaration of Incorporation. Alternatively, a door, gate or barrier specific '*universal*' control panel can be used. These should be supplied with a machinery Declaration of Conformity as they are rated as safety components by the Supply of Machinery (Safety) Regulations (Machinery Directive).

In either case, the control system manufacturer must supply a detailed installation manual, and the installation company should follow it.

Control systems must be constructed using tried and tested principles and should generally only fail to the safe condition. This should include any fall-back protection or wicket door stop switches and wiring.

#### 3.7.1. Post 2018 control systems

Control systems on doors, gates and barriers, manufactured since 2018, when EN 12453:2017 was published, are required to have all safety related parts of the control system in conformity with EN 13849-1 at minimum performance level (PL) C, throughout the entire control system, from any switch or sensing element through to the motor terminals.

This should include fall-back protection stop switch, wicket door stop switch, and the limit switch system. Limit switch circuits should also achieve a minimum of category 2 according to EN 13849-1.

### 3.8. Sensitive safety components

The system connecting safe edge and non-contact presence detection devices should be fully compatible with the control system they are connected to such that, as installed, they conform to a minimum of category 2 (according to EN 954/13849-1).

Safe edges, light grids and laser scanner devices are classified as safety components by the terms of the Supply of Machinery (Safety) Regulations (MD). Installation and maintenance companies should only use appropriate door, gate or barrier specific devices that are compliant with EN 12978 and are supplied with a manufacturer's machinery Declaration of Conformity.

The device manufacturer must also supply a detailed installation manual, which the installation company should follow.

Where the device is installed according to the manufacturer's instructions, and is covered by their Declaration of Conformity in that configuration, the system can be assumed to be compliant on that basis, unless there are obvious deficiencies.

Where there is doubt, the control system manufacturer and/or the device manufacturer should be consulted for advice on compatibility and compliance.

#### 3.8.1. Post 2018 sensitive safety devices

Doors, gates and barriers manufactured since 2018, when EN 12453:2017 was published, are required to have all safety related parts of the control system in conformity with EN 13849-1, at minimum performance level (PL) C, throughout the entire control system from any switch or sensing element through to the motor terminals. Devices used on these systems should be fully compatible with the control system in use and conform to these requirements.

As installed, they must additionally achieve a minimum category 2.

#### 3.8.2. Pre 2018 non-compliant systems

To reduce the risks arising from the lack of fail-safe on some existing non-compliant systems, or where existing category 3 devices are not fully protected from short circuit faults, a degree of mitigation can be achieved by providing:

- 1) oversized and robust conductors, and
- 2) the use of short as possible cable routing, and
- 3) the use of crimped, feruled or tinned conductor ends to prevent stray strands.

Wherever reasonably practicable, the device should be placed within the control panel, or, failing that, be connected via armoured cable or cable in conduit.

Such systems should be rated as 'requiring improvement' and the client advised to increase user checks or planned maintenance as appropriate to use and the environment.

### 3.9. Wicket door/gate stop circuit















Where a wicket door/gate is fitted in a powered system, movement of the main leaf should be prevented whenever the wicket is not in a safe position. See also 3.7.1.

### 3.10. EN 60335 parts 1 & 2

As an alternative to 3.7, 3.8 & 3.9, the entire drive, control and safety system can be manufactured and assembled to meet the requirements of:

- 1) EN 60335-1 and EN 60335-2-95 for domestic garage doors, or
- 2) EN 60335-1 and EN 60335-2-103 for industrial doors, gates and traffic barriers.

### 3.11. IP ratings for electrical equipment

1 <sup>st</sup> Digit - Solid Objects		2 <sup>nd</sup> Digit - Liquids	
1	 Protected against inadvertent contact with the back of a hand (50mm).	1	 Protected against vertical water drops.
2	 Protected against inadvertent contact with a finger (12mm).	2	 Protected against water drops falling at up to 15° from vertical.
3	 Protected against inadvertent contact with screwdrivers etc (2.5mm).	3	 Protected against water drops falling at up to 60° from vertical.
4	 Protected against inadvertent contact with small wires (1mm).	4	 Protected against water splashes from all angles.
5	 Protected against ingress of non harmful dust.	5	 Protected against low pressure water jets from all angles (eg hose pipe).
6	 Completely protected against ingress of dust.	6	 Protected against high pressure water jets (eg power washer).
		7	 Protected against temporary immersion (tested @ 1m depth 30min.)
		8	 Protected against permanent immersion (rated depth quoted).

---

### 3.12. Safe isolation procedure

#### Step 1

Check that it is safe and acceptable to switch off the system.

Switch off at the isolator and, where necessary, secure (lock off) and place warning signs, e.g. when the isolator is remote from the system to be worked on.

#### Step 2

Prove the correct operation of a safe (GS 38 compliant) voltage tester against a known voltage source (e.g. electrician's proving unit).



#### Step 3

Using the safe voltage tester, check that all circuits to be worked on are dead:

- 1) place one probe on earth, with the other check each line (live) conductor, then
- 2) place one probe on neutral, with the other check each line (live) conductor again, then
- 3) place one probe on earth, check neutral.

#### Step 4

Re-prove the correct operation of the voltage tester against the known voltage source.

#### Further guidance

HSE GS38 describes safe test equipment for electricians.

<http://www.hse.gov.uk/pubns/priced/gs38.pdf>

HSE HSG85 provides guidance on developing safe working practices for people who carry our work on or near electrical equipment.

<http://www.hse.gov.uk/pubns/priced/hsg85.pdf>

## 4. Safety distances, guards and enclosures

All hazards related to moving parts should be eliminated or controlled up to a height of 2.5m above ground level, or any other permanent access level, e.g. stairway, mezzanine floor or control cabinet. Hazards that are not reachable do not need additional control measures.

### 4.1. Surfaces, edges, and protruding parts

Sharp edges should be avoided on any part that could contact a person by removing burrs and ensuring that all edges are rounded. Protruding parts that could cause injury should be avoided by safe design wherever possible. Where this is not possible, guards or covers should be used to prevent harm.

### 4.2. Minimum distances to prevent crushing (powered)

Various minimum safety distances exist (derived from EN 349 & EN 12453) to prevent injury to differing body parts.

Crush hazard		Draw-in/shear hazard
Finger = 25mm	Leg = 180mm	Finger = 8mm (4mm at a hinge)
Hand wrist = 100mm	Head = 300mm	
Arm, foot = 120mm	Body = 500mm	

#### *Minimum distances to prevent injury*

These can only be applied or utilised at points where only that size of body part could reasonably be affected. Hence, use of these distances, other than 500mm, is restricted in many cases. For example, there is no point restricting a reducing gap to 25mm where an arm or leg could easily be inserted; the arm or leg would be seriously injured when the gap reduces to 25mm.

A gap greater than 500mm between door/gate and a fixed object eliminates the crush hazard potential at that location; this can be relaxed to 200mm within 250mm of the hinge centre on swing and folding doors & gates.

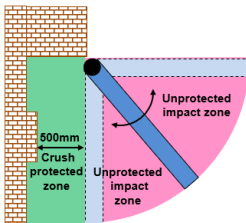

Swing door/gate

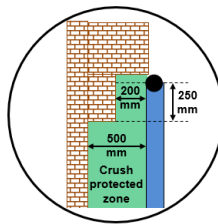

Relaxation to 200mm  
within 250mm of the hinge

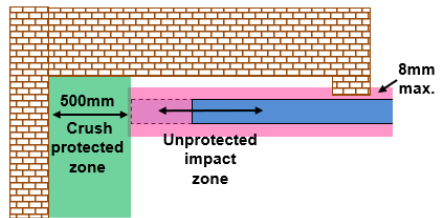

Sliding door/gate

A safe distance can only deal with the crush element, an impact hazard will always remain.

### 4.3. Gaps under hinged door/gate lower edges (powered)

A foot crush hazard can be prevented by ensuring the gap under the leaf in the swept area is:

- 1) less than 8mm or more than 120mm, and
- 2) constant, without of slopes and kerbs, etc

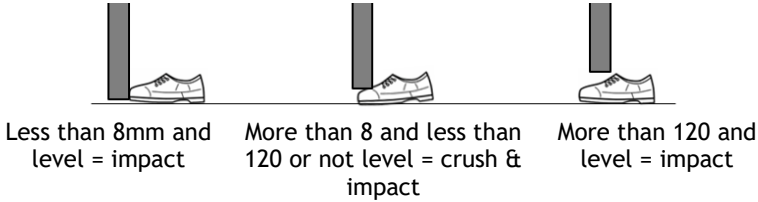

Hazards in the swept area should be controlled by one or more of the permitted control measures: hold-to-run, force limitation or non-contact presence detection. Where force limitation is used, the nature of the hazards in the swept area will dictate the maximum force that can be used:

- 3) crush & impact hazards in the swept area = 400N maximum
- 4) impact only in the swept area (no crush) = 1400N maximum.

### 4.4. Hinge area of hinged doors/gates (powered)

Reducing gaps at the hinge area can generate a very high force. Access to a reducing gap at a hinge area is possible from a variety of directions (see below).

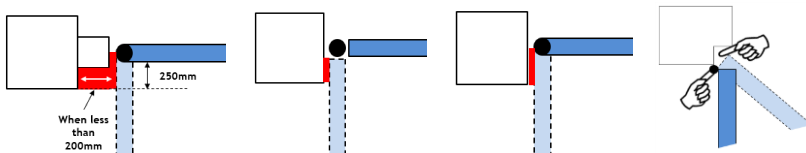

Reducing gaps at the hinge area should be avoided by safe design wherever possible.

A safe design hinge area is either:

- 1) a constant gap of less than 4mm or more than 25mm, or
- 2) where the overall gap is less than 100mm, a changing gap of 20% or less.

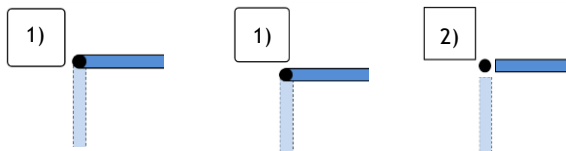

Continues →

If a safe design hinge area is not achieved, one or more of the permitted control measures should be applied: flexible guard (and, in some cases, fine mesh to prevent access through the leaf infill), hold-to-run, safe edge, or non-contact presence detection (where viable).

Flexible guards should be durable, cover the entire hazard, and not fold into the reducing gap. They will also need to be removable by key or tool for inspection and maintenance of hinges within the guarded space.

#### 4.5. Draw-in points on sliding doors/gates (powered)

Draw-in hazards, where a sliding leaf passes close to a fixed object, should be protected by one or more of the permitted control measures: fence or guard (in the runback area), safe distance (8mm max), hold-to-run, force limitation or non-contact presence detection.

Where force limitation is used, it should be provided by safe edge (not inherent force limitation) and the safe edge should be positioned as close as possible to the moving leaf, to prevent draw-in occurring.

The maximum distance allowable between the moving leaf and the safe edge is dictated by the gaps in the moving leaf. The gap should be verified using a rigid rectangular test piece measuring 120mm x 120mm x 500mm.

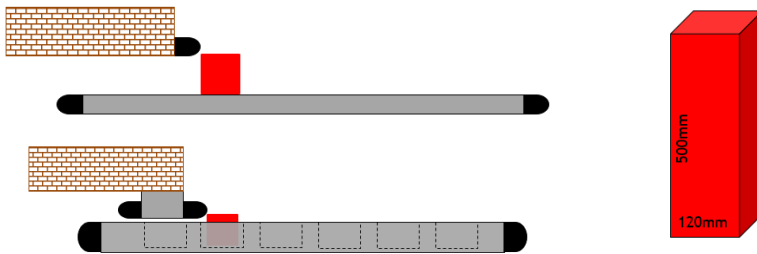

The test piece should be placed as deep as possible into gaps in the leaf; the safe edge should be in close enough to be activated by the test piece.

**Warning, the test must only be conducted in manual mode, not under power!**

EN 12453 only specifies use of the 120mm x 120mm x 500mm test piece where apertures or ledges would allow people to ride on the leaf; the standard defines this as:

- 1) where ledges protrude horizontally more than 40 mm from the leaf, and
- 2) where test probe B according to EN 61032:1998 can penetrate apertures in the leaf by more than 20 mm.

**NOTE: DHF advises that, regardless of this, the 120mm x 120mm x 500mm rectangular test piece above should be used to determine a safe distance wherever safe edges are used to protect drawing-in hazards on a sliding door or gate.**

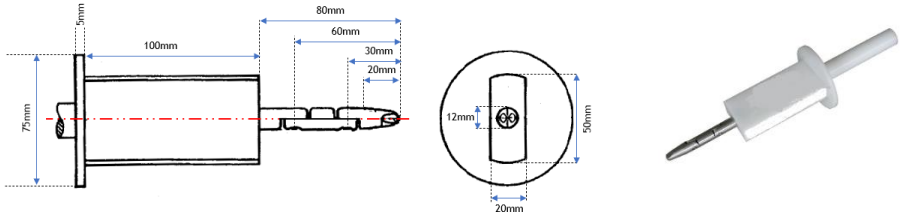

Test probe B according to EN 61032

The end of the probe tapers at 74° for 10mm and then further to 37° for the last 10mm.

#### 4.6. Draw-in at rolling shutter barrel

Whilst it is in theory possible to use a hood type structure as a guard to prevent draw-in, due to the restrictions imposed by roll diameter range and curtain deflection across the width, it is unlikely that such an arrangement would work well in practice.

EN 12453 requires that such structures are designed to meet the requirements of EN ISO 13857; the appropriate data is shown below.

People aged 14 + (tall enough to reach the headgear)	
Slot Size mm	Clearance mm
4 - 6	20
6 - 8	40
8 - 10	80
10 - 12	100
12 - 20	120
20 - 30	850

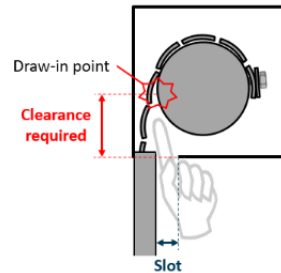

Other permitted controls are hold-to-run (see section 5), high level category 2/3 beams (see section 3.8) or the use of non-contact presence detection (see section 7) active during opening. Many domestic garage doors will not require draw-in protection - see section 11 - reduced safety for domestic garage doors.

#### 4.7. Fence or enclosure to prevent access to moving parts (powered)

Fencing or other types of enclosures can be used to prevent access to hazardous movement areas (e.g. sliding door/gate run back area). It must be understood that such structures are not security fencing, they are machine guards. This means that they should be durable, permanently fixed, only removable by key or tool and resist foreseeable misuse:

- 1) verticals on the outside & horizontal supports on the inside, with 40mm or less between verticals (to resist climbing)
- 2) conform to tables 1 and 2 (derived from EN 12453 & EN ISO 13857) for reach over and reach through protection.

Continues →

Height of guard	Height of leaf		
	2	2.2	2.4
	Horizontal clearance		
2	350	350	350
2.2	0	250	250
2.4	0	0	100
2.5	0	0	0

Table 1 - data from EN 13857

Rectangular aperture smallest dimension	Horizontal clearance
18.5 or less	120
18.6 to 29	300
29.1 to 44	500
44.1 to 100	850

Table 2 -from Annex B of EN12453

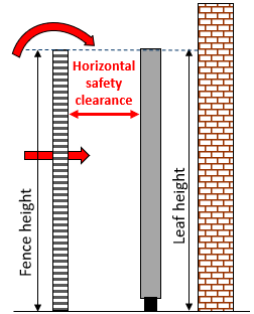

**NOTE:** Fence heights below 2m generate prohibitive reach over horizontal safety clearances and are more easily climbed by children so they are not shown. Where a leaf/fence is planned to be below 2m, DHF recommends capping the enclosure.

## 5. Hold-to-run (safety by human visual control)

The leaf should only move when pressure is being applied to the activation device, and:

- 1) release of the device leaf should not result in over travel of more than 100mm
- 2) release of the device on sliding and vertically moving leaves should not result in over travel of more than 50mm in the last 500mm of horizontal movement
- 3) the device should be designed or placed such that it can only be used in a position that allows full, direct, and permanent real-time view of the leaf during the leaf movement
- 4) the device should ensure that the person controlling the system is not in a hazardous position themselves
- 5) only one device should be active at any one time
- 6) the leaf should travel at no more than 0.5m/second; for converging leaves this means 0.25m/second each.

**NOTE:** *Hand-held portable activation devices (e.g. radio controls) can only be used for hold-to-run when their active range is so limited that point 3 is achieved. According to EN 12453, video cameras do not give a full, direct, and permanent real-time view.*

Table 1 of EN 12453 provides the following guidance.

Minimum level of protection at the main edge - hold to run		
Only trained users present	Trained users, but untrained people present	Untrained users
Unsecured H-T-R	Secured H-T-R	H-T-R not permitted

Hold to run is only permitted to be used by trained users. The presence of untrained people alters the nature of the activation device that can be used. Where untrained people might be present, the activation device must be secured, for example with a key switch or similar. As hold-to-run is reliant on trained users, the O&M manual should provide detailed instructions for use, and what to look out for (e.g. fall-back protection on vertically acting doors - see 2.3.3 - point 13).

Hold-to-run can be used to control any clearly visible **crush, impact, shear or draw-in or lifting hazard**.

## 6. Force limitation (safety by safe contact)

The maximum allowable forces and durations are as follows:

- 1) the maximum time force can exist at or below 25N is infinite ( $F_e$  - end)
- 2) the maximum time force can remain above 25N in is 5 seconds ( $F_s$  - static)
- 3) the maximum time force can remain above 150N is 0.75 seconds ( $T_d$  - dynamic)
- 4) a maximum of 400N permitted at crush, shear, and draw-in hazards:
  - horizontally reducing gaps of 500mm or less, and
  - vertically reducing gaps below 2.5m ( $F_d$  - dynamic)
- 5) a maximum force of 1400N is permitted at impact only hazards:
  - contact with a horizontally moving leaf outside of a crush, shear, or draw-in zone ( $F_d$  - dynamic).

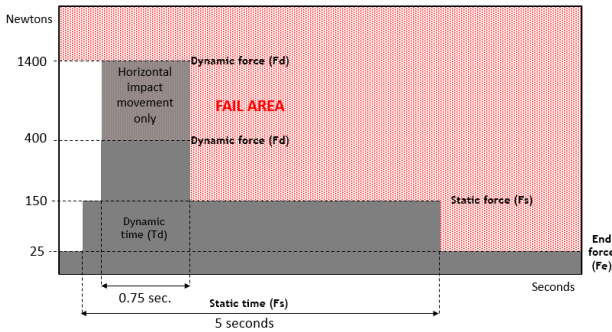

On a force tester		
$F_d$	1400N	Max
$F_d$	400N	Max
$T_d$	0.75s	Max
$F_s$	150N	Max
$F_e$	25N	Max

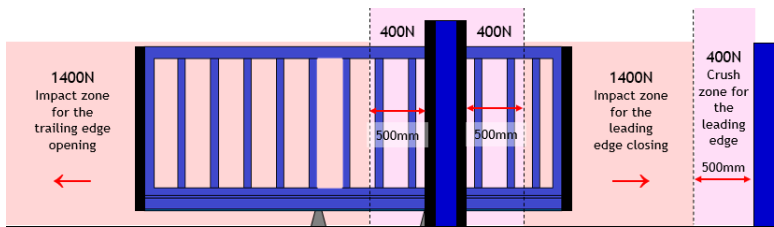
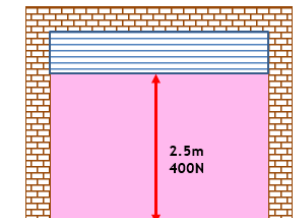
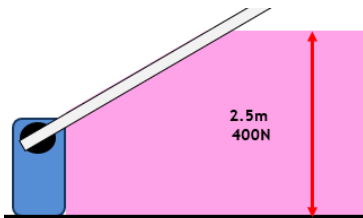

Examples of maximum force at differing hazard locations

Continues →

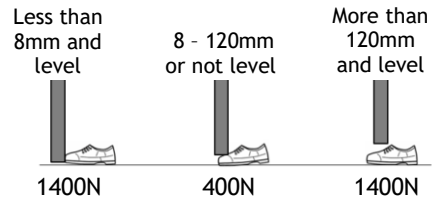
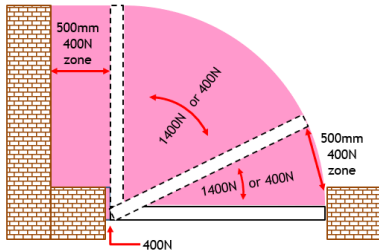

*Maximum force at differing hazard locations on hinged systems*

## 6.1. Safe edge

Force limitation can be provided by safe edge in resistive, optical, mechanical, or pneumatic format and:

- 1) the device should be UKCA/CE marked and come with a manufacturer's machinery Declaration of Conformity
- 2) the safe edge and any control device should conform to EN 12978
- 3) the safe edge should provide the permitted force and time figures
- 4) the safe edge should protect the full height/width of the crush/impact zone with the exception that the edge does not need to be sensitive in the final 30mm of each end
- 5) the control circuit should meet the requirements of 3.8.

The required safe edge specification is governed by leaf overtravel (stopping distance). The speed & weight of the moving leaf, the reversal torque of the operator and the time the control system takes to react all affect overtravel. The available overtravel in the safe edge will need to be greater than the overtravel of the leaf in all but the lightest of systems.

A safe edge can be used to control any **crush, impact, shear or draw-in** hazard.

## 6.2. Inherent force limitation

Force limitation at some hazards can be provided by sensitive drive units.

The system should reliably provide the permitted force and time figures.

Inherent force limitation can be used to control some, but not all hazards:

- 1) Inherent force limitation should not be used to control draw-in hazards. By implication, this will also apply to any associated shear hazards.
- 2) Inherent force limitation is unlikely to be able to provide safe force at reducing gaps in the vicinity of the hinge on hinged systems, particularly in reducing hinge gaps, or at the lower edges in the hinge area.

*Continues →*

These areas will normally need safe edges to provide force limitation. If inherent force limitation is to be relied upon to provide force limitation in these areas, the resulting crush force should be measured directly in that location.

- 3) Inherent force limitation systems are unlikely to provide safe force on hinged systems when subject to high winds. It will usually be necessary to rely on safe edges for force limitation on such systems, given that the system should be safe in all conditions. If inherent force limitation is to be relied upon for such a wind affected system, evidence should be provided that safe force is achieved, even in high winds.

### 6.3. Fire/smoke resisting doors

When in normal day to day use, fire and smoke resisting doors are subject to the same requirements for safety as any other door.

When closing under fire conditions, the force limitation described here is not necessarily required. But, if a person were to be trapped by a fire door closing under fire conditions, it would not then be able to prevent the spread of fire, so care must be taken to provide adequate warning where this is a possibility. See section 12, residual hazard control.

As the equipment used to provide safety on a door must be included in the fire tests, most fire resisting shutters will need to be operated in hold-to-run, as a safe edge used to provide force limitation would not fare well in a fire test.

### 6.4. Pre-production type test force measurement

Manufacturers conducting serial production type testing for UKCA/CE marking compliance should follow the relevant standard (using an approved/notified body where required by the Construction Products Regulations 2013). Applicable standards are:

- 1) EN 13421 for Construction Products Regulations 2013 (CPR), and
- 2) EN 12453 for Supply of Machinery (Safety) Regulations (Machinery Directive).

### 6.5. On site (field) force measurement

Tests should be conducted with an annually calibrated instrument that complies with EN 12453 or EN 12445. Manufacturers type testing for serial production will involve many multiples of tests, in accordance with the relevant standard but, when doing one-off testing of individual systems as part of commissioning or maintenance, a reduced number of tests is more appropriate. In general, each test position should be tested once but, where the result is in excess of 90% of the maximum permitted value, it should be repeated three times and the average of all three tests taken as the actual result.

The 90% threshold values above which an average of three tests should be used are as follows:

- 1) 360N (400N maximum) for crush hazards
- 2) 1260N (1400N maximum) for horizontal pure impact hazards
- 3) 0.68 seconds (0.75 second maximum) for force to remain above 150N

- 4) 4.5 seconds (5 second maximum) for force to remain above 25N.

Force testing is necessary on any system using force limitation, as part of commissioning new systems when adjustments are made that could alter force, and as part of regular planned maintenance.

The following sections explain necessary main edge tests applicable to all systems. Where other hazard areas of a system are also being protected by force limitation, that hazard area should be verified:

- 5) either by testing directly at the hazard (where safe or practical), or
- 6) by verification of main edge tests taken during full speed movement.

More details of verification are provided in section 6.5.3.

### 6.5.1. Force measurement points on vertically moving doors

- 1) Centre of the door with an extension on the tester that reaches in full speed movement.
- 2) With a 300mm extension on the tester:
  - 2.1. centre of the door opening
  - 2.2. at each side 200mm, in from the guides
- 3) Re-test the point of the highest reading in test 2 with no extension on the tester (50mm).

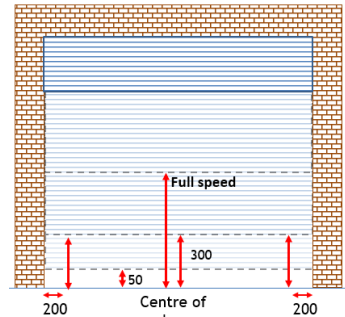

**NOTE:** The full speed test (1) is only necessary where slow-down occurs outside of the final 300mm of travel.

Where this is not the case, the tests at 300mm (2) will provide the required full speed result.

### 6.5.2. Force measurement points on horizontally moving doors/gates

Please note that a single leaf is shown; where opposing leaves are in use, the tests are conducted in the centre of the opening where the leaves come together.

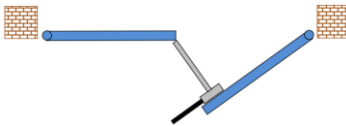

Test position with leaf delay

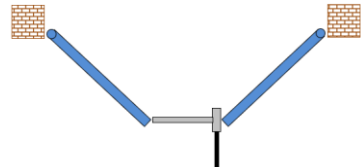

Test position without leaf delay



Sliding door/gate test position

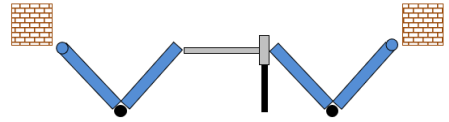

Folding door/gate test position

The door/gate should be tested in the mode in which it is to be used. If a leaf delay is used, it should be tested with that same delay; if no delay is used, the leaves should be tested as they converge:

- 1) At waist height with an extension on the tester that reaches full speed movement.
- 2) With a 500mm extension on the test meter test at three heights:
  - 2.1. top - (300mm from the top or 2.5m)
  - 2.2. middle - (mid height or 1.5m)
  - 2.3. bottom - (50mm up from the base)
- 3) Re-test the point of highest reading in test 2 with no extension on the test meter (50mm).

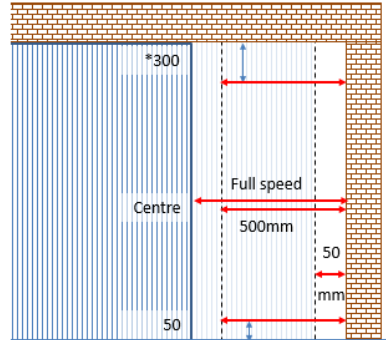

**NOTE:** The full speed test (1) is only necessary where slow-down occurs outside of the final 500mm of travel. Where this is not the case, or no slow-down is in use, the tests at 500mm (2) will provide the required full speed result.

### 6.5.3. Result assessment for hazards not tested directly – sliding

As testing at draw-in points on sliding doors/gates is not usually possible or safe, the full speed main edge result can also be used to assess safe force at other hazards in the swept area.



This method assumes that opening and closing speeds and settings are equal.

Comparing the full speed result, with the protection used on the main edge, and the protection used at other swept area crush, shear and draw-in hazards, reveals what action is necessary as explained in the following table.

Trailing edge open impact hazards can be assessed directly from the main edge test results, other crush, shear and draw-in hazards can be assessed as follows.

Full speed result at the main edge	Main edge protection	Swept area hazard protection	Result assessment outcome and required action at swept area hazards.
Up to 400N	Safe edge	Same	OK - no further testing/action required
Up to 1400N	Safe edge	Larger	<i>Not verified - test sample of the larger safe edge on the main edge</i>
Up to 400N	Safe edge	Smaller	<i>Not OK - fit equal size safe edge</i>
Up to 1400N	Safe edge	Same/smaller	<i>Not OK - fit larger safe edge</i>
Up to 1400N	Inherent	Safe edge	<i>Not verified - test sample safe edge at the main edge</i>
Up to 1400N	Inherent	Inherent	<i>Not OK - inherent force limitation not suitable for draw-in</i>

Full speed result assessment to verify sliding system draw-in/shear force

#### 6.5.4. Result assessment for hazards not tested directly – swing & folding

The full speed main edge result can also be used to assess safe force in the swept area of swing/folding doors & gates as follows:

- 1) Where the swept area does contain crush hazards, the full speed main edge test should result in 400N or less, or
- 2) Where the swept area does not contain crush hazards, the full speed test at the main edge could result in as much as 1400N.

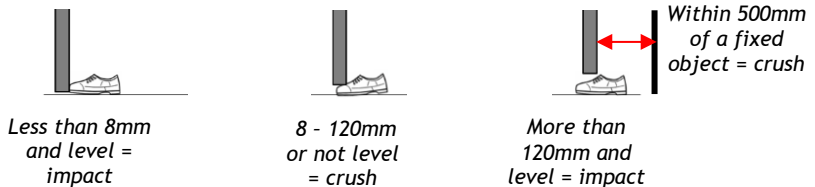

Comparing the full speed result with the protection used at the main edge, and the protection used at the hazard being assessed, can reveal what action is necessary. This is explained in the following table.

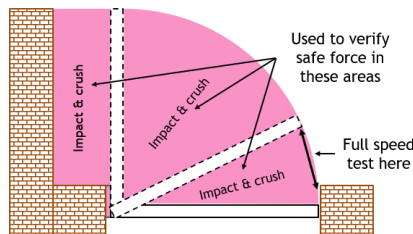

Continues →

Full speed result at the main edge	Main edge protection	Swept hazard area protection	Swept area hazard	Result assessment outcome and required action at the swept area hazard
400N or less	Safe edge	Safe edge	Crush	OK - no further testing/action required
401N to 1400N	Safe edge	Safe edge	Impact only	OK - no further testing/action required
400N or less	Safe edge	Inherent or smaller safe edge	Crush	Not verified - safe edge/larger safe edge needed in the area close to the hinge, or measure force at the hazard
401N to 1400N	Safe edge	Inherent or smaller safe edge	Impact only	Not verified - test inherent at the main edge (away from the safe edge)
400N or less	Inherent	Inherent	Crush	Not verified - safe edge needed in the area close to the hinge, or measure force at the hazard
401N to 1400N	Inherent	Inherent	Impact only	OK - no further testing required

*Full speed result assessment to verify hinged system swept area safety*

### 6.5.5. Force measurement points on traffic barriers

The measurement should be taken with a 2m maximum extension fitted to the tester:

- 1) 200mm in from the tip of the arm
- 2) and at an angle that results in the face of the tester being parallel with the arm.

Lightweight gravity deployed skirts (not fixed or link operated skirts) may be tied up out of the way for the test.

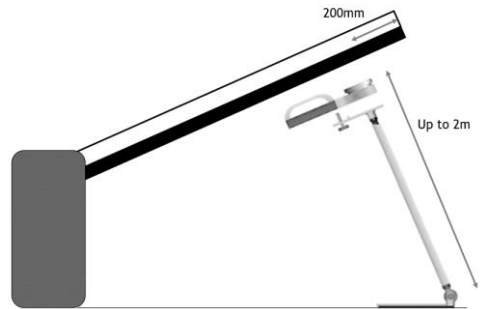

**NOTE:** *the maximum force under a barrier is 400N.*

## 6.6. Supplementary device

Force limitation is not considered to be universally safe. Where users are untrained, the means of activation is remote from the system, or there is reasonable possibility that untrained people will be affected, supplementary devices for the detection of people (e.g. photo beams) must be added. This is to reduce the probability of contact with force limited movement.

The supplementary device should be active somewhere between 700mm and the ground, and no more than 200mm horizontally from the face of the leaf and active across the entire width.

For hinged doors and gates, where an inner device is used, it should be active no more than 200mm horizontally from the open extremity of the swept area.

For traffic barriers, either one device active directly below the arm, or two devices, one on either side within 200mm of the arm are permitted.

Table 1 of EN 12453 provides the minimum level of protection necessary at the main edge when using force limitation.

Activation	Users present		
	Only trained users present	Trained users, untrained people present	Untrained users
Impulse activation in sight	No supplementary device needed	No supplementary device needed	Supplementary device required
Impulse activation out of sight	No supplementary device needed	Supplementary device required	Supplementary device required
Automatic	Supplementary device required	Supplementary device required	Supplementary device required

### 6.6.1. Post 2018 sliding or vertically acting systems

Systems manufactured after 2018 (since publication of EN 12453:2017), with a distance greater than 150mm between the device and the opposite face of sliding and vertically moving leaves, are required to have a device active on both sides.

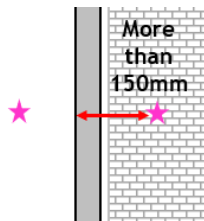

## 7. Non-contact presence detection

Non-contact presence detection systems are those that can prevent a person from being touched by the moving leaf. When a system is fully protected by non-contact presence detection, there is no need for force limitation, but the system must be tested for effectiveness, and the following:

- 1) The device should be UKCA/CE marked and come with a manufacturer's machinery Declaration of Conformity
- 2) The device should be compliant with EN 12978
- 3) Any background field auto adjust time should be at least 30 seconds
- 4) As installed, the system should meet the requirements of section 3.8.

Single beam photo electric beams are not included, unless they can exclude all possible contact with the hazard, for example, when attached to the lower edge of a vertically moving door or barrier.

There are two permitted methods of providing protection:

- 5) Acting directly in the movement plane of the door/gate:
  - acting within or through drillings in the guides (e.g. shutters), or
  - a device mounted on and traveling with the main edge (see 'd' below)
- 6) Acting to create safety zones on both sides of the door/gate, extending a distance 'd' horizontally from the face of the door/gate/barrier:
  - related to the speed and height of the door, but no less than 200mm, and
  - dimensioned to activate before a person can be contacted

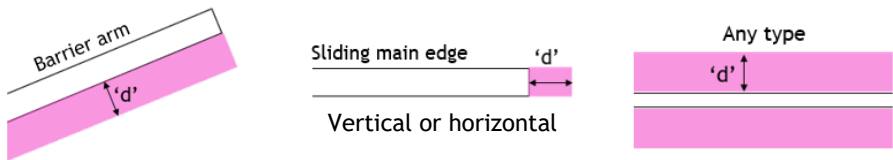

Compliance and effectiveness of the system is not verified by configuration or mounting position, but by testing.

Non-contact presence detection technology can be used to control any **crush, impact, shear, draw-in or lifting** hazard. There are no limits on the presence of untrained persons or means of activation with this type of protection.

**NOTE:** *Be aware that these systems can be subject to nuisance tripping due to adverse environment and weather conditions (heavy rain, snow, wind-blown debris or animals and birds). Where systems can be de-sensitised to accommodate these effects, they should still pass the tests set out below and will require re-testing following any adjustments.*

## 7.6. Pre-production type testing

Manufacturers engaged in serial production type testing for UKCA/CE marking compliance should follow the relevant standard (using an approved/notified body where required by the Construction Products Regulations 2013), applicable standards are:

- 3) EN 13421 for Construction Products Regulations 2013 (CPR), and
- 4) EN 12453 for Supply of Machinery (Safety) Regulations (Machinery Directive).

## 7.7. Fire/smoke resisting doors

When in normal day to day use, fire and smoke resisting doors are subject to the same requirements for safety as any other door.

When closing under fire conditions, the protection described here is not necessarily required. But, if a person were to be trapped by a fire door closing under fire conditions, it would not then be able to prevent the spread of fire, so care must be taken to provide adequate warning where this is a possibility. See section 12, residual hazard control.

As the equipment used to provide safety on a door must be included in the fire tests, most fire resisting shutters will need to be operated in hold-to-run as a device used to provide protection would not fare well in a fire test.

## 7.8. On-site (field) testing

On site testing as part of commissioning or maintenance, is conducted with rigid material test pieces as follows.

### Test piece A

Rigid material 700mm x 300mm x 200mm.  
Painted matt black on three sides RAL 7040, grey on the other three.

*Used for impact and whole-body simulation.*

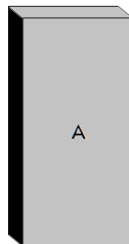

### Test piece B

Rigid cylinder 300mm x 50mm painted half matt black and half RAL 7040 grey.



*Used for arm, hand and foot simulation.*

The reaction of the system to an activation of the device will be crucial. In some locations, the resulting reversal can result in un-protected movement at other hazards. For this reason, pause, stop, or even emergency stop may be the required reaction to activation on some systems. No contact with hazardous movement is permitted in a successful test.

**NOTE: Machine safety legislation dictates that activation of a safety system at one hazard location should not create further hazards on other parts of the machine.**

### 7.8.1. Device active within the swept area (vertical)

This test method only applies where the protective device is active directly within the swept area of the leaf. For example, a light grid mounted within, or acting through drillings in, the guides of a rolling shutter. Such systems use sequential switching as the main edge blocks the beams in turn as it closes.

*Continues →*

Alternatively, a single beam fixed on, and traveling with the main edge can achieve an equal result.

Test piece A should be placed in the path of the closing leaf anywhere between 300mm and 2.5m, and test piece B anywhere below 300mm.

No contact should occur.

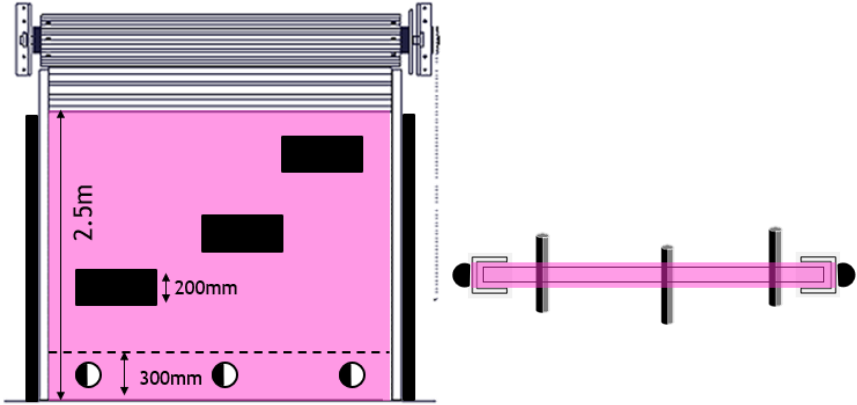

*Test piece A is oriented with the 200mm dimension vertical.*

### 7.8.2. Devices active to either side of the movement plane (vertical)

This test method applies where the device is not active within the swept area.

For example, light grids or laser scanners mounted to either side, the leaf moving within a narrow (200mm max) unprotected zone.

The A test piece should be offered towards the protected area, no contact should occur.

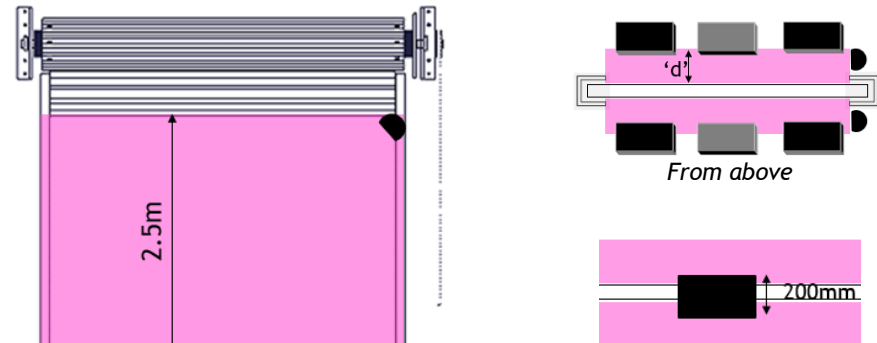

*Oriented with the 300mm dimension vertical*

*Placed on the floor with the 200mm dimension horizontal to test the dead zone*

### 7.8.3. Devices mounted on either side of a sliding door/gate

Test pieces A & B should be presented towards the moving leaf at all hazard areas from both sides. Test piece A should be used at impact hazards and test piece B should be used at crush, shear and draw-in hazards.

Movement should cease before the test pieces are impacted, crushed, sheared or drawn-in. Test piece A is also placed in the dead zone with its 200mm dimension horizontal to the leaf; no movement should be possible.

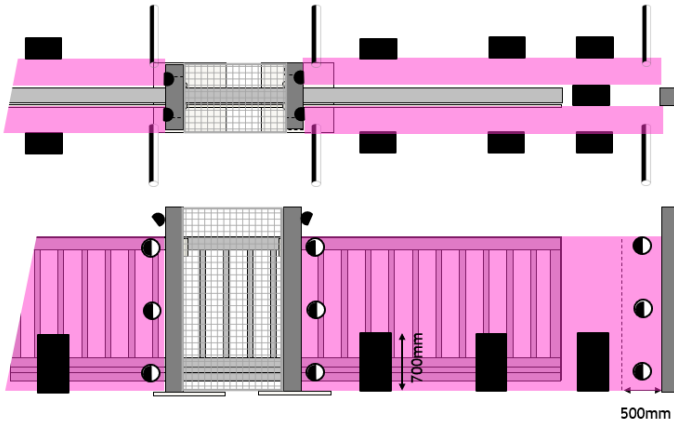

*Test piece A is oriented with the 700mm dimension vertical*

### 7.8.4. Devices mounted on and moving with hinged doors/gates (horizontal)

Test pieces A & B should be presented towards the moving leaf at all hazard areas from both sides. Test piece A should be used at impact hazards and test piece B should be used at crush hazards.

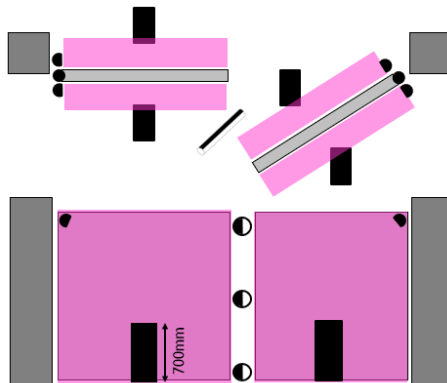

*Test piece A is oriented with the 700mm dimension vertical*

*Continues →*

Hazardous movement should cease, or the leaf should reverse, before the test piece is impacted or crushed. If the leaf reverses, the leaf should remain protected during the reversal movement.

### 7.8.5. Devices mounted on and moving with folding doors/gates

Test pieces A & B should be presented towards the moving leaf at all hazard areas from both sides. Test piece A should be used at impact hazards and test piece B should be used at crush hazards.

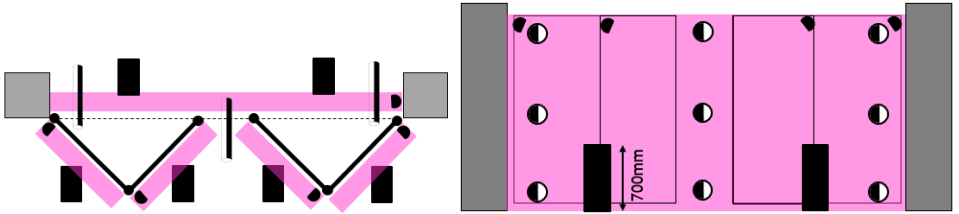

In this example, 4 x laser scanners are protecting the inner surfaces and a single light grid is protecting the outer face. The threshold device will need to activate ‘emergency stop’ in order to prevent crush or impact within the “V” between the leaves.

If the leaf retracts, the leaf should remain protected during the reversal movement.

### 7.8.6. Testing non-contact presence detection on traffic barriers

- 1) In this example, a single laser scanner is providing an exclusion zone ‘d’ either side of the arm.

Test piece A should be offered to all points at the periphery of the protection zone from both sides with the 700mm dimension vertical.

Contact with hazardous movement should be prevented.

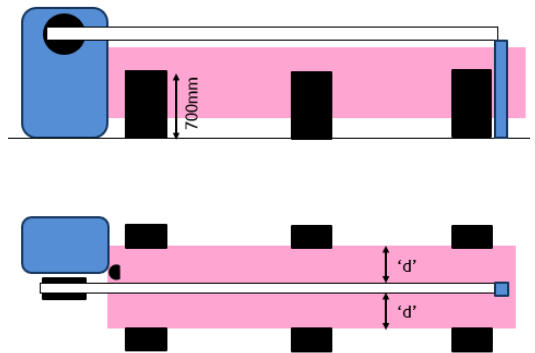

- 2) In this example, two laser scanners or light grids are used to provide a 2.5m high exclusion zone either side of a barrier fitted with a linkage operated (fixed) skirt that has crush hazards in the skirt as the arm raises.

Test piece A should be offered to all points at the periphery of the protection zone from both sides during closing (700mm dimension vertical). Test piece B should be offered to reducing gaps associated with the skirt during opening.

Contact with hazardous movement should be prevented.

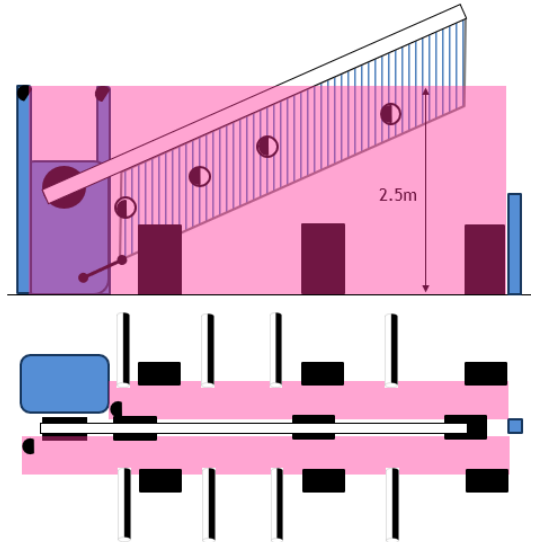

## 8. Lifting hazard control

Wherever possible, a powered door should be designed so that there are no useable hand or foot holds that might give rise to a person being carried aloft by the door either by accident or misuse.

EN 12453 defines the following as presenting hand/foot holds:

- 1) where ledges protrude horizontally more than 40 mm from the leaf, and
- 2) where test probe B according to EN 61032:1998 can penetrate apertures in the leaf by more than 20 mm.

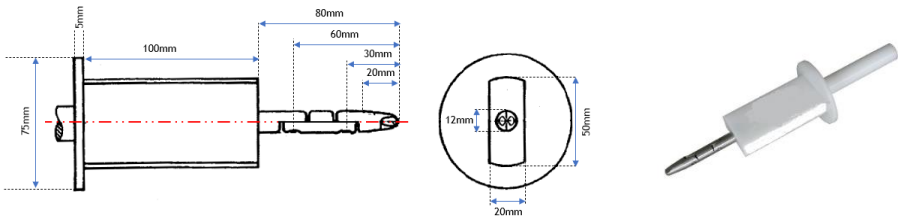

*Test probe B according to EN 61032*

The end of the probe tapers at 74° for 10mm and then further to 37° for the last 10mm.

To present a lifting hazard, there would need to be a ledge to stand on and a hand hold higher up from the foothold.

Where lifting potential cannot be prevented by removing potential hand & foot holds, a control measure should be implemented to prevent lifting of persons; the available options are one or a combination of:

- 3) operate the door in hold-to-run
- 4) limit drive torque such that the leaf cannot lift a test weight of 20kg (domestic) or 40kg (industrial/commercial), mounted centrally on the lower edge of the door
- 5) install high-level category 2 or 3 photo beam(s) (see clause 3.8) that will detect a person before they reach a hazardous height and/or location
- 6) install non-contact presence detection active during opening.

Thought should be given to what occurs when a person is detected by protective high-level beam; it is not acceptable to lift a person so high that they become injured when they fall, or to leave them suspended at a dangerous height. Use of a photo beam is only practical where the beam is less than 3m above ground.

## 9. Imprisonment hazard control

An imprisonment hazard is caused when the door or gate is the only route out of an enclosed area where people can come to harm. In such environments, a manual release should be provided at the door or gate. Where untrained users will be affected, user instructions should also be displayed.

The door should remain safe when being used in manual mode and also when power is restored unexpectedly.

**NOTE:** *Depending on the location and use, fire safety regulations may require additional escape means that are less restrictive to use - e.g. push bar swing doors. Very few automated doors or gates could achieve the ease of use required for an emergency escape route in a multi occupancy building.*

Care must be taken to ensure that the system will not contravene fire safety legislation. The DHF guide to industrial & garage door, powered gate & traffic barrier legislation TS 013-2:2021 provides more detail on fire safety legislation.

## 10. Manual doors & gates

This guide is focused on vehicle access doors and gates within the scope of EN 12604. The structural integrity information in section 2 applies equally to manual vehicle gates.

Use of the manual opening and closing systems should not introduce hazards. Moving the leaf in manual should be achievable with ease. Where more than one person is required to move the leaf in manual mode, the user instructions should explain this. A safe force for one person to move a leaf in manual is 150N in domestic and 260n industrial environments.

Where a manual gate is provided with a spring closer, care should be taken to protect reducing gaps at the hinge and under the gate close to the hinge.

This guide does not cover manual pedestrian gates, they are outside the scope of EN 12604. However, BS 5709:2018 (for the UK) does provide some useful guidance for pedestrian gates, for example:

- 1) 6.3.2 Self-closing - *“springs without speed control shall not be used as a means of closing”*
- 2) 6.3.6 Opening force - *“pedestrian and bridle gates shall swing freely and a force not greater than 18 N shall be needed to open them fully in the absence of wind forces”*
- 3) 6.3.12 Trapping - *“one-way opening gates which close onto a closing post rather than onto a latch, to avoid trapping, the overlap at the closing line on the closing post shall be at least 30 mm”*

Continues →

DHF offers a degree of caution. The scope of BS 5709 is restricted to 'new gates for footpaths, bridleways, restricted byways and other routes used by the public. It can also be used for gates to be installed on permissive paths, wholly private ways and on commons' so it may or may not be completely appropriate. Whichever route is taken, the gate must be safe for the intended users.

## 11. Powered pedestrian gates

The scope of EN 12453 does not cover horizontally moving pedestrian-only entrance systems, these are covered by the automatic door standard EN 16005. Whilst it is not an absolute legal requirement to use the appropriate designated (harmonised) standard, an equal or improved degree of safety must be achieved.

In higher risk environments, where there will be high numbers of children or vulnerable adults using the door, EN 16005 requires the use of non-contact presence detection over force limitation. Non-contact presence detection according to EN 12453, as explained in section 7, provides an equal degree of protection.

Where the environment or the gate design does not lend itself to EN 16005 automatic door operators and associated optical safety devices, safety could alternatively be provided using a combination of force limitation and supplementary beams according to EN 12453, as explained in section 6.

DHF advises that, if force limitation in combination with supplementary beams is to be employed, the maximum force should be kept much lower than the 400N permitted by EN 12453 (e.g. 150N to match EN 16005) and that the supplementary devices should be employed on both sides of the swept area. This should be applied together with a combination of additional residual hazard controls (see section 13).

## 12. Reduced levels of safety for domestic garage doors

Reduced levels of safety are permitted where a vertically moving domestic garage door is provided for the use of a single domestic household and:

- 1) it does not open directly onto a public highway, and
- 2) it does not use automatic closing.

Under these conditions, it is permitted to protect only the main edge of the moving door. Other draw-in, crush or shearing hazards may be disregarded; for example, draw in at the roll of a rolling door or control linkages on older retractable doors.

Fall-back protection must always be provided.

**NOTE:** *If auto close is subsequently enabled, additional measures may be required.*

### 13. Residual risk assessment & control

A residual risk is the risk that remains after the state-of-the-art has been achieved, for example, the effects of being subject to 399N for 0.74 seconds. For very young or infirm people, the effect of residual risk could in fact be significant and, hence, the residual risk assessment should attempt to reduce the degree of harm possible. Where high risk exists (e.g. at a school), non-contact solutions, even lower force than the standard allows or additional beams should be given the highest priority.

Vehicle related hazards should be considered and provided for at this stage as the state-of-the-art is primarily concerned with the safety of people, not vehicles.

Residual risks can be controlled by applying suitable measures, e.g. one or a combination of the following, shown in order of merit for the protection of vulnerable users:

- |                            |                        |                       |
|----------------------------|------------------------|-----------------------|
| 1) non-contact             | 7) activation devices  | 13) traffic lights    |
| 2) very low force          | 8) pedestrian railings | 14) vehicle detectors |
| 3) additional photo beams  | 9) signage             | 15) traffic calming   |
| 4) warning lamps           | 10) zone lighting      | 16) user warnings     |
| 5) LED warning strips      | 11) hazard tape        | 17) user instructions |
| 6) audible warning devices | 12) ground markings    | 18) user training     |

Selection of appropriate residual controls should be arrived at based on a local risk assessment. Unlike the main body of hazards dealt with by the state-of-the-art, where the focus is on the potential degree of harm, the control of residual risks can be based on likelihood of occurrence and frequency of exposure.

The need for residual hazard controls reduces as the likelihood of contact with a residual hazard diminishes on a given site. Great care is required none the less as, in the event of an incident, the findings of the residual risk assessment will be brought into judgement to some degree at least. Written user warnings, safe use instructions and user training should be provided and are an important aspect of residual hazard control.

Great care must be taken with fire/smoke resisting doors. If a person were to be trapped by a fire door closing under fire conditions, it would not then be able to prevent the spread of fire, so care must be taken to provide adequate warning where this is a possibility. In many cases, fire/smoke resisting doors will require audio & visual warning systems.

#### 13.1. Example residual hazard signs



*Door moves without warning or gate/barrier*



*Keep clear door moves towards you*



*Trip hazard*

*Continues →*



*Dangerous voltage within*



*Hazard*



*Hazard area*



*Stop*



*No entry*



*One-way*



*Pedestrians*



Oncoming  
vehicles have  
priority

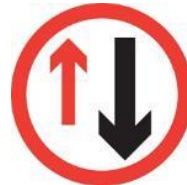

Priority over  
oncoming  
vehicles

## 14. Non-compliance

Due to machinery safety and construction products legislation, the responsible company (manufacturer) must ensure that new systems they supply are compliant and safe.

For existing systems under maintenance or repair, the compliance assessment is essentially the same, except that the ultimate legal responsibility is the owner's or manager's.

However, if a maintenance company does not leave a system in a safe condition following maintenance, they can and do face criminal prosecution.

Some non-compliances are worse than others. To assist with this, in maintenance environments only, DHF has produced a list of safety critical and requiring improvement hazards:

- **Safety Critical** = should not be returned to service
- **Requiring improvement** = can be restored to service, if the client understands the non-compliance and authorises it

<b>Safety Critical</b> Should not be returned to service	<b>Requires Improvement</b> Could be left in service with client agreement
Structural failure imminent	Minor structural improvement necessary
Crush, shear, draw-in or impact hazard not protected below 2.3m above permanent access level (easy to reach)	Crush, shear, draw-in or impact hazard not protected but between 2.3m and 2.5m above permanent access level (hard to reach)
Force or time limits over maximum: – Crush/shear/draw-in hazard over 500N – Impact hazard over 1750N – 150N exceeded for over 1s – 25N exceeded for over 10s	Force or time limits over maximum: – Crush/shear/draw-in between 401 & 500N – Impact hazard between 1401 & 1750N – 150N exceeded between 0.76 & 1s – 25N exceeded between 5.1 10s
Vertically acting door with lifting potential but no protection	Safe edge/non-contact presence detection, performance correct but not category 2 or 3 as installed
Fire resisting door with defects that would affect its ability to resist fire	Hinge strength unknown but judged to be safe currently
Hold-to-run in use, some hazards not visible	Hold-to-run by radio fob
Hold-to-run overtravel over 125mm	Hold-to-run by insufficiently trained users
Sliding leaf without adequate travel stop	Hold-to-run overtravel between 100 & 125mm
Structural failure due to wind probable	Hinged door/gate without travel stops
Safety fence or guard provided but easily defeated	Safety fence mesh size/clearance incorrect but only defeated by extreme action
Sliding door/gate safe edge at draw-in hazard fails test piece test and is more than 140mm	Sliding door/gate safe edge at draw-in hazard fails test piece test but less than 140mm
Main edge crush/impact hazard protected solely by horizontal low level photo beams.	Safety brake, cable or spring break device not wired to stop circuit as per installation manual
Suspension element of vertically moving door terminally worn or damaged	Vertically moving door with fall-back protection but further use not prevented
Vertically acting door without fall-back protection (except manual drop bar type fire shutters or with high level pin locks - see over)	Vertically moving door without fall-back protection but fitted with pin locks at fully open + additional user training/management
Wicket door/gate without stop circuit	Vertically acting, pre-July 2013, manual, spring balanced, permanently held open (only closes at fire signal) fire door, without fall-back protection (e.g. drop bar fire shutter).
	2 hinge inverted pin system but appears sound
	Insufficient supplementary beams
	Danger of vehicle impact or impact to vehicle
	Insufficient residual hazard controls
	Insufficient maintenance
<b>Electrical Hazards</b>	
Class 1 electrical equipment not earthed	RCD required but not fitted
Exposed live conductors	Unprotected cable in good condition
Damaged cabling - safety or power circuit	IP rating incorrect but appears safe currently

This list is not exhaustive, other hazards exist. When this is the case, a similar ethos must be applied.

## 14.1. Leaving in a safe condition

Leaving in a safe condition following maintenance can mean many things, depending on the system and what the safety defects are, but could include one or a combination of:

- 1) reversion to manual use
- 2) reversion to, or provision of, hold-to-run
- 3) secured against collapse
- 4) closed and switched off - vertically acting doors without fall-back protection (best)
- 5) open with pin locks fitted - vertically acting doors without fall-back protection (2<sup>nd</sup> best)
- 6) open and switched off - tube motor shutters without fall-back protection (3<sup>rd</sup> best)
- 7) switched off - where the problem is moving safety, or electrical.

In most cases, it would be sensible to leave a sign, label or tag on an unsafe system:

- 8) it should include the maintenance company's contact details
- 9) explain the safety issues to users or site representatives where possible
- 10) it would be wise to take a photograph of the sign in place.

The maintenance company should also issue the client with an unsafe system notice by traceable means, e.g. email or recorded post.



*Example unsafe system sign*

## 14.2. Certificate of compliance

Once a system under maintenance has been made safe, a certificate of compliance can be issued. This is a DHF designed document, intended to be issued where an existing system has been made safe & compliant, but a new door/gate has not been created.

### 14.3. Example certificate of compliance

Job reference: Tyres-R-U's NT1 3TN.

Site address: Industrial Park, Back lane, Newtown.

Postcode: NT1 3TN

Reason for issue:

~~N/A New system~~      ~~N/A New maintenance contact~~      ~~N/A Repair~~       Modification

Assessment conducted by: F Bloggs

#### Structural integrity

- Foundations, supports, barrels, shafts, bearings, welding & fixings are provided secure & resilient
- Guides, tracks, rollers and hinges are secure, aligned and resilient
- ~~N/A Steel wire ropes properly aligned, correct specification and undamaged~~
- Travel stops secure, properly aligned and resilient
- Fall-back protection provided (vertically moving doors)
- Resistance to wind load correct for environment
- ~~N/A Safety distances to prevent crush hazards correct~~
- ~~N/A Fencing is secure and has the correct safety clearances~~

#### Electrical safety

- Earth connections correct and secure       Cabling is secure and protected mechanically
- Wire terminations correct and secure       Cable sizes and specifications correct
- Enclosures and cable entries sealed       Dangerous voltage labels in place
- Supply conforms to BS 7671/ET 101       Conductive metalwork continuity to earth is tested
- Isolation is functional       Electrical tests completed
- Safety devices achieve category 2 or 3 as installed

#### Functional tests and settings

- Limit switch/system properly set       Operating logic correct for safety in use
- Safety device function & system response correct       Photo beam function and response correct
- Fall-back protection devices issue a stop command on deployment
- ~~N/A Wicket door switches operate e stop~~      ~~N/A Loop detectors operate correctly~~
- Intercoms, keypads, key switches, buttons, transmitters etc operate the correct command
- The system operates as designed

---

### Safety performance tests

~~N/A Hold-to-run overtravel measured~~

~~N/A Non-contact presence detection tested~~     Force limitation tested

~~N/A Force test results assessed and indicate safe force at all hazards protected by force limitation~~

### Warning devices, signage and markings

Warning devices, signage and markings provided as per the residual risk assessment

Warning lamps function correctly    ~~N/A Audible warning devices function correctly~~

~~N/A Road markings in place and visible~~     Warning signs in place, visible & comprehensible

~~N/A Pedestrian barriers in place and secure~~    ~~N/A Pedestrian routes marked and visible~~

### Compliance assessment

All hazards identified     All hazards correctly controlled

Residual hazards correctly identified     User warnings explain residual hazards

Safe use instructions reflect the residual hazards

### Maintenance

Maintenance instructions adequate     Maintenance interval adequate

Maintenance tasks completed    Maintenance interval 6 months

### User information

User training completed     User warnings provided and explained

User instructions provided and explained     Maintenance instructions provided and explained

Maintenance log provided (new systems) and updated (existing systems)

~~N/A Declaration of Conformity provided (new systems)~~    ~~N/A UKCA/CE label fitted (new systems)~~

On the date indicated this system is in full compliance with DHF TS 012:2019, is safe and at that time satisfied the legal obligations of both the owner and the maintaining company

Completed by: **Fred Bloggs**    Signature: **FWB**    Date: **11 Feb 2021**

## 15. Fire Resisting Industrial Doors (additional guidance)

Whilst much of the design and construction of fire doors is shared with ordinary industrial doors, there are important differences in the specification, installation, operation, and maintenance of fire resisting industrial doors.

### 15.1. Evidence of conformity and performance

The required performance specification for a particular project should have been provided by the client or their principal designer. They will have arrived at the required specification by reference to their fire prevention and emergency egress plan for the building, in accordance with the appropriate national Building Regulations.

Since November 2019, evidence of conformity and performance of a fire resisting industrial door is the manufacturer's Declaration of Performance. This may be supported by a copy of the manufacturer's Certificate of Constancy of Performance, issued to them by their certification body. Certification is provided in accordance with EN 16034 by the certification body, who will have overseen the testing to EN 1634, and applied the relevant extended application, classification and factory production control assessments. The door should bear either UKCA or CE marking as appropriate to the country of installation. UKCA/CE marking does not infer suitability for a project on its own, it merely states the performance achieved.

For existing doors, evidence of compliance is more complicated to assess. Prior to November 2019, evidence of conformity was provided by one or more of:

- 1) a copy of fire test report, where the door is the same size or smaller than the tested sample
- 2) a copy of letter of assessment from a fire engineer, based on a fire test report, where the door is larger than the tested sample
- 3) a copy of the certificate issued by an independent fire certification body.

Whilst these are no longer legally sufficient for new doors, they are acceptable evidence of compliance for doors placed on the market prior to November 2019; test evidence for these doors may be based on BS 476 or EN 1634.

### 15.2. Supporting Construction

The structure supporting the door must have fire resistance at least equal to that of the door. It must also be a material covered by the manufacturer's certification. Certification given against one construction material cannot be used for a differing construction material.

### 15.3. Installation

Installation must be carried out strictly in accordance with the manufacturer's installation manual by trained and experienced personnel. Fixings must be steel and be of a type, dimension and penetration approved by the manufacturer. Fixing holes will generally be slotted to allow for expansion of the shutter under fire conditions, with nylon washers commonly used to allow the expansion to occur. All materials used on the installation must have the same or better fire rating as the door.

*Continues →*

Should additional materials to those provided by the manufacturer be required, advice should be sought from them prior to use and approval for use gained in writing.

Where gaps occur between the door and the supporting structure, these should be filled as follows:

- i. larger gaps (exceeding 10mm) should be filled with a non-combustible packing material secured in position, and then sealed using a fire resisting sealant
- ii. smaller gaps (not exceeding 10mm) should be filled with fire resistant sealant
- iii. all materials used should be as approved by the manufacturer.

#### **15.4. Safety in use**

Fire resisting shutters are subject to the same requirements for safety in use as any other door, as per sections 2 -13 of this guide.

Closing under fire conditions may be via local heat sensor or alarm activation as per the fire safety plan for the building. Local heat sensors are usually specified for areas where all hope of life is lost before the shutter is closed; this is usually the only option permissible where shutters are on an escape route. Alarm activation usually requires some form of audio/visual warning prior to movement of the shutter as per the installation residual risk assessment.

#### **15.5. Maintenance**

Maintenance of fire door should only be carried by trained and experienced personnel. The evidence of compliance and performance should be reviewed by the maintenance company prior to taking on maintenance of a fire door.

The instructions in the O&M manual should be followed, including all inspections, function checks and tests specified. Any damage to the shutter or supporting structure should be noted and reported to the client.

Leaving a fire door in a safe condition is more complicated than with an ordinary door. Leaving the door out of service could seriously compromise fire safety, whilst leaving it in service in a safety critical condition could also put building occupants at risk. The decision must be taken following discussion with the client and a risk assessment of the safety of the door and the overall fire safety of the building. In many cases, the door will have to remain in service, but the client may need to apply additional site and user controls to maintain user safety until safety can be restored.

#### **15.6. Repair**

Repair of fire doors should only be carried by trained and experienced personnel, using materials specified by the manufacturer. Additional safety products (e.g. safety brakes) can only be retrofitted with the written authority of the manufacturer. Should replacement materials be fitted without authority from the manufacturer, the fire performance of the door may be compromised, and the responsibility for any failure in a fire situation will most probably lie with the person or company who carried out the repair.

---

## 16. Information and training

DHF offers a range of training courses for site and office-based personnel:

<https://www.dhfonline.org.uk>

- 1) Level 2 Award in Industrial & Garage Door Safety - for site, office and managerial persons - covering safety in use and compliance
- 2) Level 2 Award in Automated Gate & Traffic Barrier Safety - for site, office and managerial persons - covering safety in use and compliance
- 3) Level 4 Award in Industrial & Garage Door and Automated Gate & Traffic Barrier Legislation - for managerial, supervisory and office persons - covering legal obligations, technical files, declarations and UKCA/CE marking

Fire safety courses are offered in partnership with the Building Research Establishment (BRE): <https://www.dhfonline.org.uk/training/fire-doors-and-shutters-training/17.htm>:

- 4) Fire Door Inspection
- 5) Timber Fire Door - Installation, Repair & Maintenance
- 6) Installation and Maintenance of Steel Hinged Fire Door
- 7) Fire shutter Installation & Maintenance

NVQ qualifications for this industry are available from Entrance Systems Alliance (DHF/ADSA partnership): <https://www.esa.uk.com/>

CSCS cards for this industry can be obtained via DHF:  
<https://www.dhfonline.org.uk/cscs-card.htm>

A wide range of guidance material is available from the DHF website publications area:  
<https://www.dhfonline.org.uk/publications/technical-specifications/1.htm>:

- 8) Best Practice Guides
- 9) Technical Specifications
- 10) Safety & Security
- 11) UKCA/CE Marking
- 12) Consumer Information
- 13) General Information

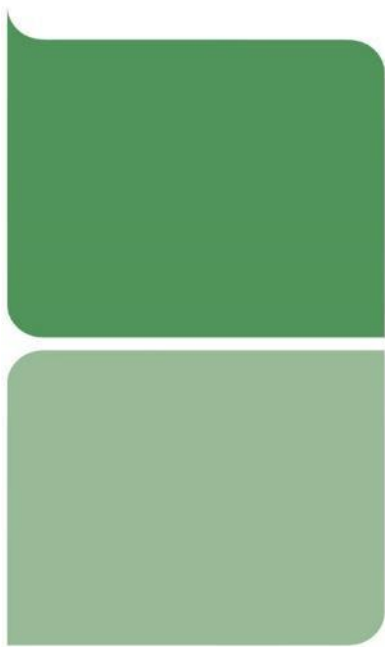

## Contact us for more information

Email: [info@dhfonline.org.uk](mailto:info@dhfonline.org.uk)

Telephone: (0)1827 52337

Address: **dhf** The Barn, Shuttington Fields Farm, Main Road, Shuttington, Tamworth B79 0HA

© Copyright **dhf** (Door & Hardware Federation) 2021

No part of this publication may be reproduced in any form without prior permission in writing from **dhf** E&OE