



DIVA

Brushless road barrier
for passages up to 3 m

BENINCA[®]
TECHNOLOGY TO OPEN





24vdc

Brushless road barrier for passages up to **3 m**



BRUSHLESS MOTOR, CONTINUOUS USE

integrated control unit, encoder and battery charger



FAST AND RELIABLE

24 Vdc barrier for continuous use, equipped with integrated control unit, encoder and battery charger. Electric motor with brushless technology that guarantees fluid movements and a very long lifespan of the operator. This represents the ideal solution in contexts requiring a continuous duty cycle. 115/230 Vac, 50/60 Hz switching power supply that permits reduced power consumptions and a longer lifespan of the operator. Highest performance and speed (opening at 80° in 0.8 s)



STURDY AND DURABLE

Gear motor entirely made of metal, in **oil bath**, with main gear in bronze alloy, allows minimising the wear process and guaranteeing an **extremely long lifespan (MCBF = 5 million cycles)**

INTEGRABLE AND CONNECTED

Thanks to the serial communication with the control unit it is possible to integrate the product with parking management systems or, thanks to the accessory **X.BE**, in **KNX** home automation systems. It is also designed for the programming through the app **BE.UP** and the interface **PRO.UP**



CONTROL UNITS:

DIVA ————— CP.DIVA

BENINCA

100% Made in Italy

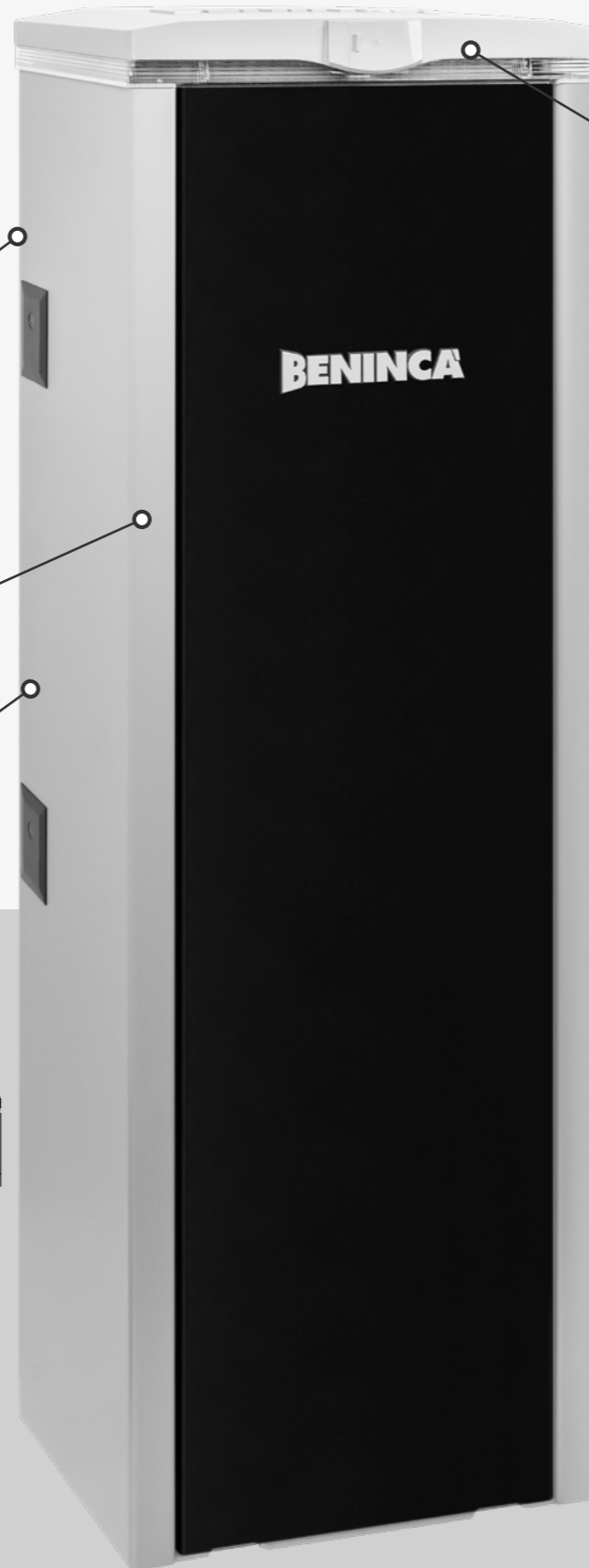

FOR ACCESS MANAGEMENT



ADJUSTABLE LED RGB (TRAFFIC LIGHT FUNCTION)

FAST ACCESS TO THE CONTROL UNIT

The upper cover is characterised by a lock with a personalised key for the opening and hinges that facilitate the installation and the wiring operations

RGB LED LIGHTS INTEGRATED IN THE COVER AND ON THE ARM

Patented illumination and diffusion systems of RGB LED lights on both the cover and the arm designed to guarantee the maximum visibility in every direction and work as footpath lights under the arm itself. Possibility to work as a flashing light, a presence light with fixed colour, settable through the wiring. It is also possible to set 4 operating modes of the boom lights thanks to a dedicated logic

Foundation plate VE.PS not included

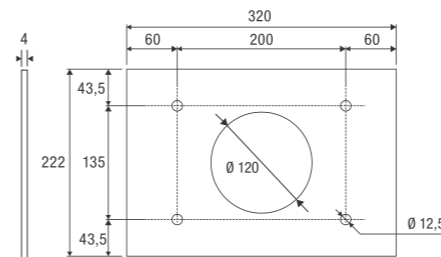

SAFETY AND DESIGN

- Through the accessory DIVA.TL it is possible to adjust the light colours according to the boom position (traffic light function) or to personalise the light colour choosing among 8 colours available. For each of them it is possible to set the value of light intensity on 5 levels.
- **Electronic slowdowns during the opening and the closing** con with the possibility to adjust the acceleration and deceleration ramps, obtaining the most fluid movements according to the boom configuration.
- **Amperometric sensor obstacle detection system to prevent crushing and encoder management.**
- **STC System device** that enables torque management in relation to the position of the door, ensuring maximum safety.

INSTALLATION SCHEME:

1. CONTROL UNIT
2. PHOTOCELL RECEIVER
3. PHOTOCELL TRANSMITTER
4. LED LIGHTS ON THE ARM
5. LED LIGHTS ON THE COVER
6. KEY RELEASE

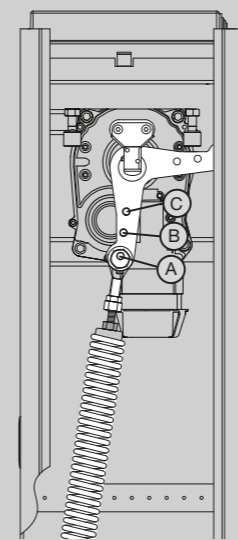
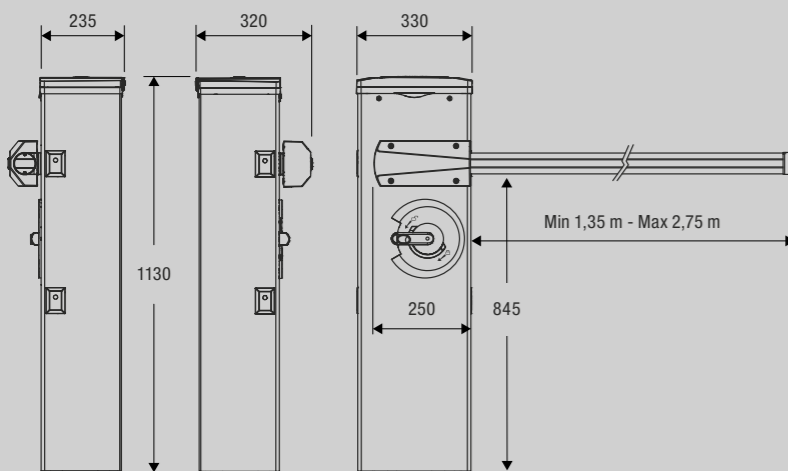
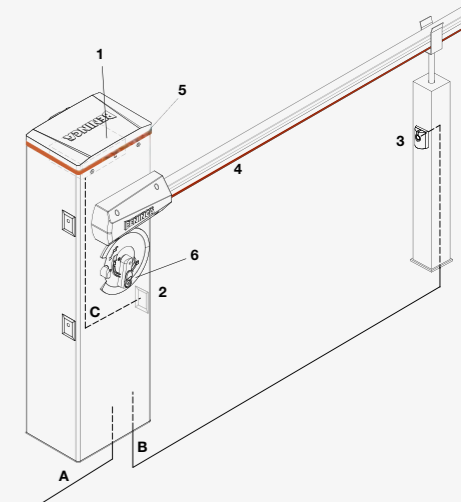

EASY ADJUSTMENT OF THE BOOM BALANCE

Spring for the boom balance provided as standard. Easy and fast adjustment and replacement of the spring for the product maintenance.

POSITIONING OF THE SPRING

Arm length	from 1,6 m to 2,0 m	from 2,0 m to 2,5 m	from 2,5 m to 3,0 m
Hook point	C	B	A

TECHNICAL DATA	DIVA.3
Power supply	115 Vac / 230 Vac (50-60 Hz)
Motor supply	24 Vdc BRUSHLESS 3PH
Max. absorbed current	1,5A (230Vac)
Power consumption in stand-by	≤ 6 W
Opening time	opening at 80° in 0.8 s
Duty cycle	continuous use*
Daily cycles	15'000**
MCBF	5 million cycles
Protection level	IP44 ((control unit IP54)
Operating temperature	-20°C /+50°C
Lubrication	OIL
Weight	49 kg
Items no. per pallet	9

(*) For continuous use at 50° C ambient temperature, the use of accessory DIVA.FAN is recommended.

CP.DIVA

CONTROL UNIT POWER SUPPLY

115 or 230 Vac (selectable) 50/60Hz

MOTORS POWER SUPPLY

24 Vdc three-phase brushless

Automatic, semi-automatic and deadman logic | Autosetting of operation parameters | Electronic torque adjustment with automatic calculation for each point in the stroke (STC SYSTEM) | Separate electronic adjustments of opening and closing speeds | Anti-crushing safety through amperometric detection and encoder management | Electronic slowdowns in opening and closing | Preparation for the operation of opposed barriers with SIS synchronisation board (optional) | Advantouch system to configure parameters and manage radio transmitters | Number of manoeuvres | Programming access password | Maintenance warning | Multi-flat function | Photocell input active both in opening and closing phases | Logic for photocell test | Logic for fast closing after photocell activation

KNX system connector (X.BE card).
Programming and diagnostics via the **BeUP** app (with **PRO.UP** card)

LCD display with three programming buttons

Switching power supply
115 or 230 Vac

Built-in battery charger compatible
with DA.BT2 and DA.BT6 batteries

Removable terminal blocks

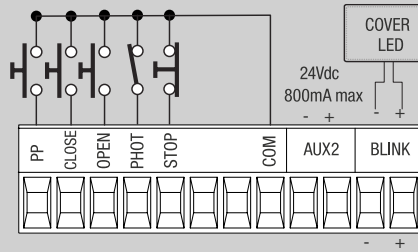

Input safety sensor during release.

Auxiliary outputs for configuration as open barrier indicator light, second radio channel, boom lights, courtesy light, verified photocell power supply, maintenance indicator, close contact when the barrier is open or closed

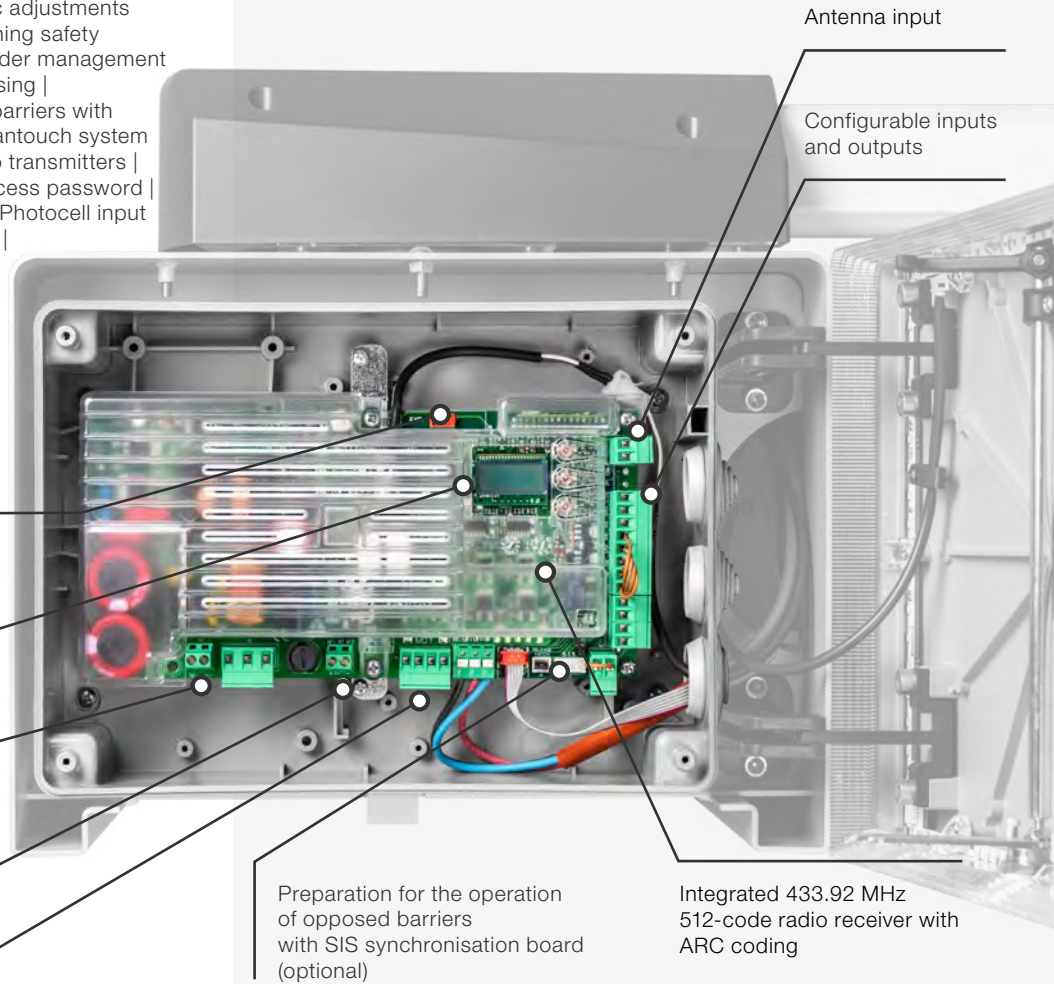

ACCESS COVER TO THE CONTROL UNIT WITH CUSTOMISED KEY AND HINGES THAT ALLOW THE COVER TO ROTATE

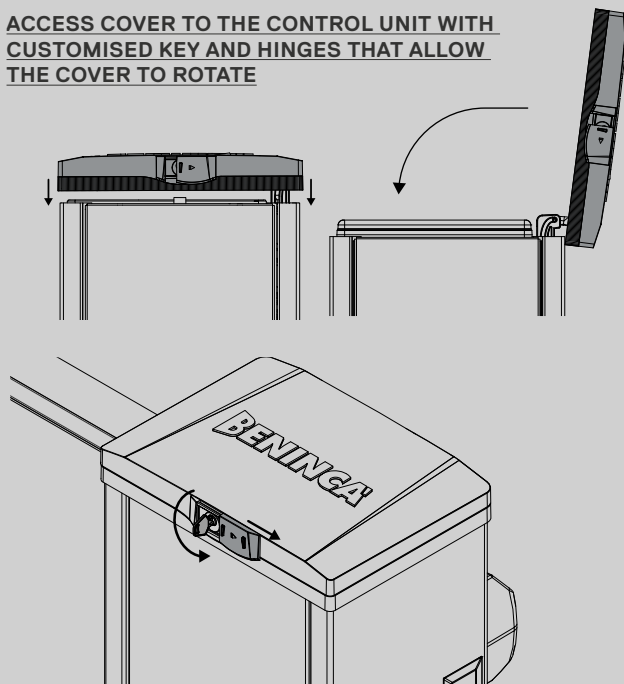

Benincà's connectivity

BeMOVE. AN APP FOR END-USERS

BeMOVE is the app that quickly connects your lights, automations, and garden irrigation system. You can control them through access time slots or **GPS positions**. This way, you can open the gate while you are getting home. With the Event function, you can easily make whatever you want, whenever you want. Even if you are not home. The **gateway HOOP** is the system's core. It interacts with the automations in mono and bidirectional mode as well as in a radio or wired mode. **g.MOVE** bidirectional transceivers show you the automation status. For example, if you have left the gate open, you can remotely check whether the lights are on. When you are away from home, you can check the automation status and enable them if needed using the **BeMOVE app**. You can also close the awnings if it starts raining.

The future is here.



g.MOVE



868 MHz module to install on control units for remote control through automation apps.

hhoop
GATEWAY



Dialogue interface between the app and the connected devices.

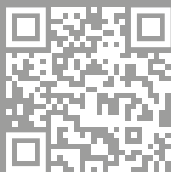

BeUP. ESPECIALLY FOR PROFESSIONALS

Working smartly

BeUP is the new application for iOS and Android operating systems, dedicated to professionals. If combined with **PRO.UP**, it allows you to programme all Benincà control units in a fast and easy way, while being comfortably seated in your lorry. Moreover, by connecting **PRO.UP** to the **cloud server**, you can save the installations made for a specific system. For future maintenance, you can also consult the system's details, past interventions and update the firmware. There's more! The app allows you to program the **BeMOVE** systems, be always updated with the latest products, consult instruction manuals and access training courses.

Choose to do the best work you possibly can.

PRO.UP

Remote programming and diagnostics interface.



**DIVA3.AL**

Fiberglass arm complete with LED lights and profile for light diffusion.
Equipped with cap (L = 3 m).

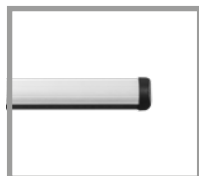
**DIVA3.AB**

Fiberglass arm without LED lights, equipped with cap and shockproof rubber (L = 3 m).

**VE.PS**

Foundation plate with coach screws.

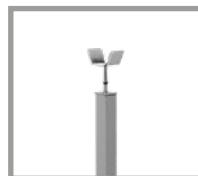
**EVA.AF**

Painted fixed support.

**EVA.SUP**

Support for DIVA internal accessories.

**DIVA.TL**

Electronic board to adjust the light colours on the arm and the crown according to the boom position (traffic light function).

**VE.CS**

Traffic-light control unit for LED.TL.

**LED.TL**

2 light 230 Vac LED traffic light.

**SIS**

Quick connection electronic board that allows synchronised movement of 2 automation devices (opposed barriers). One board for each motor is necessary.

**DIVA.FAN**

Cooling fan.

**LSR.B**

Laser opening and safety sensor for barriers, EN12453 type E certified. Adjustable detection field up to 9.9 m x 9.9 m.

**TX.LSR**

Remote control for the adjustments of LSR sensors.

**VE.KM1HN**

Single channel loop detector.

VE.KM2HN

Two channels loop detector.

**CABLE.L6**

Pre-assembled loop detector with 6 m connecting cable
Package of 6 m.

CABLE.L10

Pre-assembled loop detector with 10 m connecting cable
Package of 10 m.

**FTC.S**

24 Vac/dc surface mounting photocell. It is possible to synchronise up to 4 pairs of photocells.

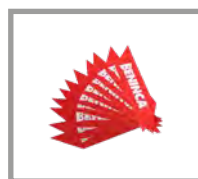
**CAT.20**

Set of 20 adhesive refractor strips.

BENINCA
TECHNOLOGY TO OPEN

AUTOMATISMI BENINCA SpA

Via del Capitello, 45
36066 Sandrigo (VI) ITALY
T +39 0444 751030
sales@beninca.com

www.beninca.com